

客户(CUSTOMER): 珠海格力电器股份有限公司(GREE)

TOSOT 物料代码 \_\_\_\_\_

GREE 物料代码 \_\_\_\_\_

# 压缩机规格书

COMPRESSOR SPECIFICATION

型号(MODEL): **QXA-C165rC030**

## 需方确认 (CUSTOMER CONFIRMATION)

确认(AFFIRMED BY): \_\_\_\_\_

审核 (CHECKED BY): \_\_\_\_\_

审定 (PROVED BY): \_\_\_\_\_

标准化(STANDARDIZED BY): \_\_\_\_\_

批准( APPROVED BY): \_\_\_\_\_

## 供方确认 ( SUPPLIER CONFIRMATION)

编制 ( DESIGNED BY): 潘登 2010.12.22

审核 ( CHECKED BY): 周明杰 龙英 2010.12.22

审定 (PROVED BY): 王方明 2010.12.22

批准( APPROVED BY): 陈国 12.23

珠海凌达压缩机有限公司

ZHUHAI LANDA COMPRESSOR CO., LTD.

# 目录

## Contents

一、适用范围 <b>Application Scope</b> .....	<b>1</b>
二、规格特性 <b>Specifications &amp; Characteristics</b> .....	<b>1-4</b>
1、压缩机规格 Compressor data	
2、电机规格 Motor data	
3、电器部品 Electrical component	
4、性能 Performances	
5、使用条件 Application conditions	
6、运行温度及压力 Operating temperatures and pressures	
7、过载保护器特性 Overload protector property	
三、注意事项 <b>Cautions</b> .....	<b>5-6</b>
四、附件及图纸 <b>Accessories &amp; Drawings</b> .....	<b>7-12</b>
1、压缩机附件 Accessories	
2、压缩机相关图纸 Drawings	

## 适用范围

➤ 适用范围 APPLICATION

此规格适用于 QXA-C165rC030 全封闭式压缩机

This specification is applied to QXA-C165rC030 rotary compressor.

用途 Application	房间空调器 Room air-conditioner
冷媒 Refrigerant	R410A
最大冷媒充注量 Refrigerant charge limit	1450g MAX
额定电压/频率/相数 Rated Voltage/Frequency/Phase	208-230V/60Hz/1 PHASE

## 规格特性

1. 压缩机规格 COMPRESSOR DATA

压缩机类型 Compressor type	全封闭型电动机压缩机 Hermetic motor compressor
泵体类型 Pump type	旋转式 Rotary
气缸数 The number of cylinders	单缸 single cylinder
气缸名义工作容积 Cylinder nominal volume	16.5 cm <sup>3</sup>
冷冻油牌号 Brand of refrigerant oil	RB68EP 或 FVC68D
冷冻油充注量 Refrigerant oil charge	400 ml
重量(含冷冻油) Weight(Refrigerant oil included)	14.5 kg
吸气管内径 Suction pipe I.D.	Φ12.2±0.05 mm
排气管内径 Discharge pipe I.D.	Φ9.7±0.06 mm

2. 电机规格 MOTOR DATA

电机类型 Motor type	感应式电机(PSC) Induction motor(PSC)	
启动类型 Starting type	电容启动 By capacitor	
极数 Pole	2 poles	
额定输出功率 Rated output power	1390	W
额定转速 Rated rotation speed	3450	rpm
绕组电阻 (25℃) Winding resistance	主相(Main) 1.61 ± 5% Ω	副相(AUX.) 2.50 ± 5% Ω
绝缘等级 Insulation class	B	

3. 电器部品 ELECTRICAL COMPONENT

名称 Name	规格 Specification
运行电容 Running capacitor	35μF/450V
过载保护器 Overload protector	内置式过载

4. 性能 PERFORMANCE

➤ 额定性能 RATED PERFORMANCE

项目 Item	标准工况 ASHREA condition	单位 Unit
制冷量 Capacity	4880 ± 3%	W
输入功率 Input power	1680 ± 3%	W
能效比 C.O.P.	2.90	W/W
工作电流 Working current	7.9 ± 5%	A
堵转电流 (240V/60Hz) L.R.A.	38	A
噪音 (A 计权声压级噪音值) Noise(A weighed sound power)	≤ 69	dB
振动 (切向加速度) Vibration(Tangential acceleration)	≤ 15	m/s <sup>2</sup>

➤ 一般性能 GENERAL PERFORMANCE

最低启动电压 Minimum starting voltage	187V/60Hz	
运行电压范围 Range of run voltage	额定工况 Rated condition	187V-242V
	过负荷工况 Overload condition	198V-242V
压缩机开停次数 Compressor cycle	≥60000	次
气密性试验压力 Leak test pressure	4.3	MPa
残余水份含量 Residual moisture content	≤200	mg
杂质含量 Impurity content	≤100	mg

➤ 安全性能 SAFETY PERFORMANCE

电气强度 Electrical strength	1500V/min 或 1800V/s, 泄漏电流不大于 5mA 1500V/min or 1800V/s, leakage less than 5mA	
壳体耐压试验压力 Shell test pressure	>10.5	MPa
绝缘电阻 Insulation resistance	>30	MΩ
接地电阻 Grounding resistance	≤0.1	Ω

➤ 测试工况 TESTING CONDITION

测试工况 Testing condition	标准工况 ASHREA condition	过负荷工况 Overload condition
测试电源 Testing power supply	220V/60Hz	220V/60Hz
蒸发温度 Evaporating Temp.	7.2℃	12℃
冷凝温度 Condensing Temp.	54.4℃	65℃
液体温度 Liquid Temp.	46.1℃	/
吸气温度 Suction Temp.	35.0℃	25℃
环境温度 Ambient Temp.	35.0℃	43℃
测试风速 Testing air flow	1m/s	1m/s

5. 使用条件 APPLICATION CONDITION

蒸发温度范围 Evaporating Temp.	-15℃~+15℃
冷凝温度范围 Condensing Temp.	27℃~67℃

6. 运行温度及压力 Operating temperatures and pressures

项目 Item	标准条件 Standard load condition	过负荷条件 Overload condition
最大压缩比 Maximum compression ratio	6.5	11
排气压力 Discharge pressure Mpa {kgf/cm <sup>2</sup> G}	3.4{33.5}以下 MAX	4.4{43.0}以下 MAX
吸气压力 Suction pressure Mpa {kgf/cm <sup>2</sup> G}	(0.6-1.3) /{5.9-12.8} -10 °C~+14 °C	(0.5-1.3) /{4.9-12.8} -15 °C~+15 °C
排气温度 Discharging Temp.	105°C MAX	115°C MAX
电机绕组温度 Motor winding Temp.	115°C MAX	130°C MAX

7. 过载保护器特性 Overload protector property

动作特性 Action characteristic	动作温度 Action temperature	140 °C±5 °C
	复位温度 Reset temperature	(80-95) °C
初动作特性 First action characteristic	电流 Current	39 A
	动作时间 Action time	(3~10)S
过负荷特性 Overload characteristic	120 °C (9.2-15.2) A	

## 注意事项

### ➤ 压缩机使用注意事项 PRECAUTIONS ON OPERATION

1. 压缩机内部已封入了 0.025~0.05MPa（表压）的干燥氮气，使用时应先拔掉高压侧(排气管)的橡胶塞，否则冷冻油会喷出压缩机。  
Compressor is charged with 0.025~0.05MPa dry nitrogen , remove high pressure side (discharge tube side) rubber plug first before application, otherwise refrigerant oil will gush from the compressor.
2. 不得有水溅入压缩机内。  
The compressor should not be splashed with water inside.
3. 压缩机不得在空气中持续打开 15 分钟以上。  
The compressor should not be left open in the atmosphere for more than 15 minutes.
4. 压缩机不得自身抽真空及空运转，系统抽真空应保证抽到真空度为 133Pa 以下。  
The compressor should not be operated to form a vacuum and to absorb air; the evacuation of the system shall ensure that the vacuum is below 133Pa.
5. 当压缩机处于真空状态下，不应向密封接线柱上加电脉冲。  
The electric pulse should not be applied to the hermetic terminals when the compressor is under vacuum.
6. 压缩机与配管，配管与配管之间的焊接应注意决不能让焊药、灰尘等杂质进入制冷系统。  
Take care that the foreign matters like solder, dust, etc will not get into the refrigerating system from soldering/welding joints between compressor and piping, as well as between piping.
7. 只使用规定的制冷剂 R410A，制冷剂应从制冷系统冷凝器的尾端注入，而不能直接注入压缩机，当制冷剂量超出规定值时，应同我公司联系。  
Only R410A is permitted. Refrigerant should be charged from the end of the condenser of the refrigerating systems. Never charge refrigerant to the compressor directly. When the charge amount exceeds designated value, contact us.
8. 在压缩机稳定运行时，系统内温度不应低于-35℃，以防止油中蜡的成分沉淀。  
Temperature within systems during stable compressor operation should not be less than -35℃ to prevent the wax in the oil from precipitation.
9. 压缩机起动运行前应确保接线正确，每两次起动应间隔 3 分钟以上，绝对禁止压缩机反向运转和在空气中运行。  
Make sure that wiring is correct before starting the compressor, the duration between two start-ups shall exceed three minutes, it is forbidden to run compressor in reverse direction and in the air.

10. 在装配系统时应保证系统洁净，为防止毛细管等堵住，必须在制冷回路中装上过滤器。  
Keep the system clean during assembly, the filter shall be assembled into the refrigerating loop to prevent block up of capillary tube etc.
11. 压缩机已装入了规定的适量冷冻油，使用时不得增加或减少。  
Do not reduce or increase the refrigerant oil during application as the compressor has been charged with specified amount of oil.
12. 为保证制冷系统的油流回压缩机，在设计管路时气体的最小速度，水平管内为 4m/s，垂直管内为 7m/s。  
To ensure the oil inside the refrigerating system returns to compressor, when designing the piping, the minimum gas velocity is 4m/s for horizontal pipe, and is 7m/s for vertical pipe.
13. 为了防止制冷剂液体积蓄在压缩机中，应保证压缩机壳体底部的温度大于冷凝温度。  
To prevent the liquid refrigerant accumulation in the compressor, ensure that the temperature at bottom of compressor case is higher than the condensing temperature.
14. 运行频率必须在额定频率的±2%范围之内。  
The running frequency shall be within ±2% of the rated frequency.
15. 压缩机在倾斜角 5°范围内可以正常运转。  
The compressor shall operate properly with tilting angle below 5°.
16. 禁止压缩机横放、倒置、跌落，不要把压缩机放置在露天，必须将压缩机存放在-10℃~+65℃的室内。  
Do not put the compressor horizontally or put it upside down. Do not let the compressor falls off. Do not put the compressor in the open air, put the compressor inside the room where the temperatures inside range between -10℃~+65℃.



附件及图纸

1. 压缩机附件 ACCESSORIES

名称 Name	数量 Quantity	说明 Description
接线柱护盖 Terminal cover	1	已配备 Loaded
螺母 Nut	1	已配备 Loaded
减振垫圈 Grommet	3	已配备 Loaded
绝缘垫 Gasket	1	已配备 Loaded
电容 Capacitor	1	客户自配 Not loaded

2. 压缩机相关图纸 DRAWINGS

名称 Name	代号 Symbol
外形尺寸图 Outside dimension	QXA-DW-01
性能曲线图 Performance diagram	QXA-DW-02
电气安装及底脚安装图 Wiring & mounting plate installation	QXA-DW-03
铭牌 Name plate	QXA-DW-04
接线柱护盖 Terminal cover	ZE7.852.059
减振垫圈 Damping washer	ZE8.639.601
绝缘垫 Gasket	ZE8.683.058A

外形尺寸图  
OUTSIDE DIMENSION  
型号 (MODEL): QXA-C165rC030

PAGE: 8/12

QXA-DW-01

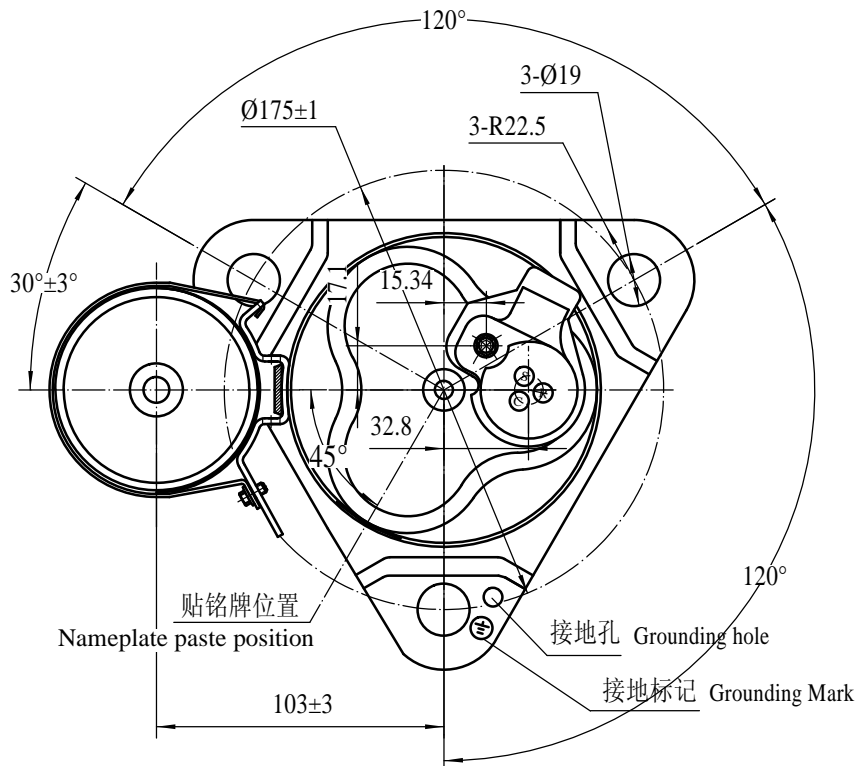
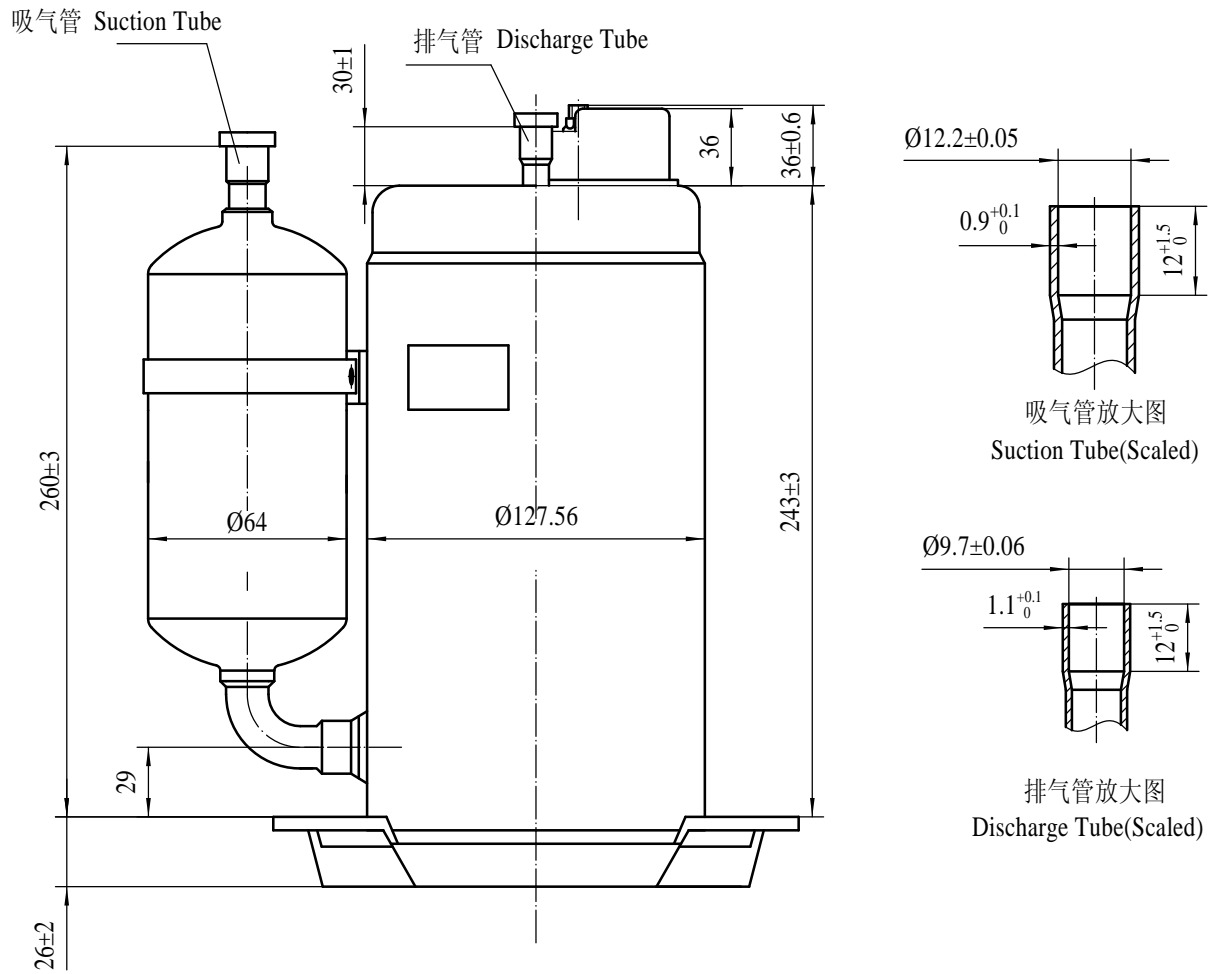

# 性能曲线图

PERFORMANCE DIAGRAM  
型号 (MODEL): QXA-C165rC030

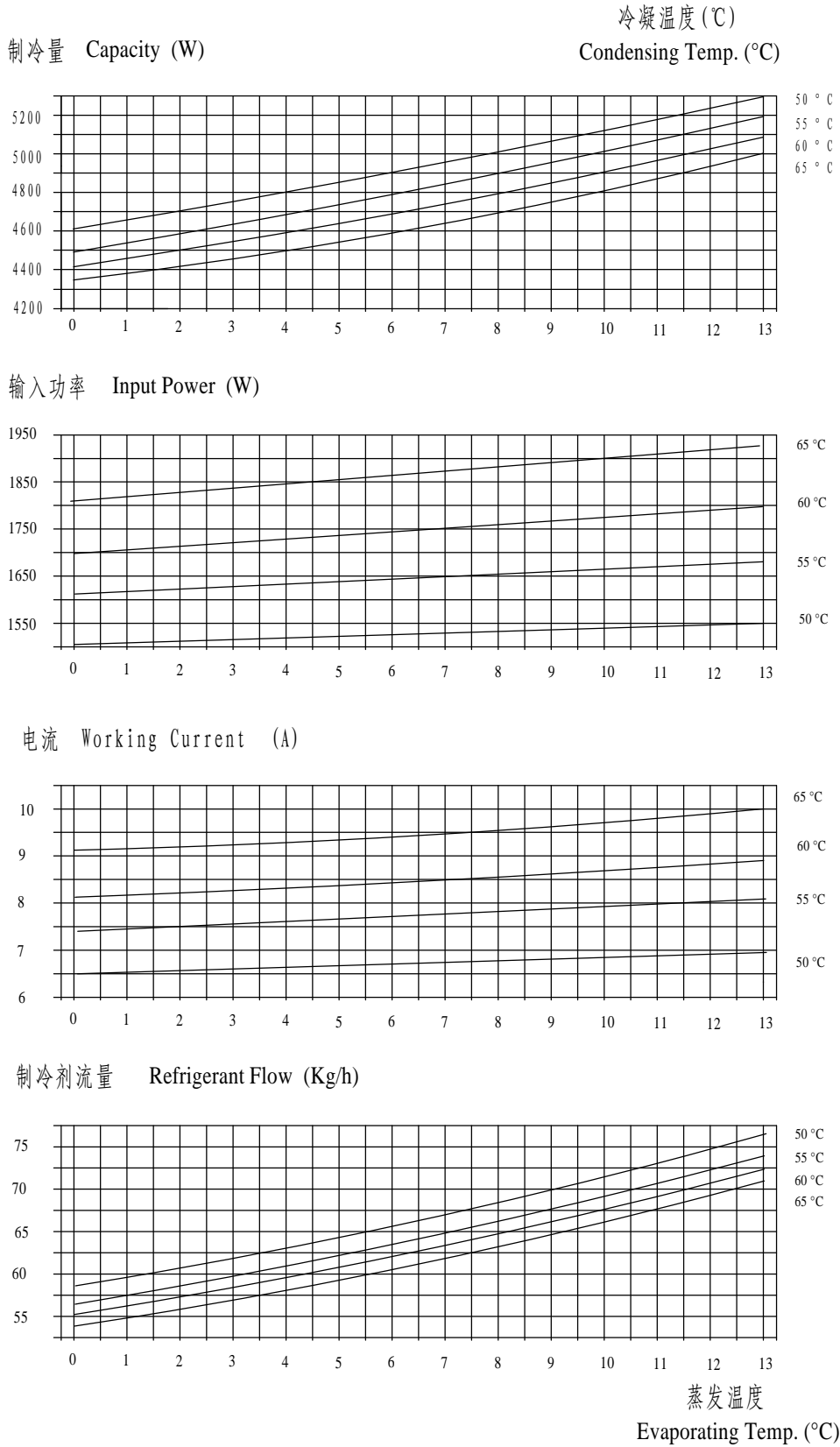

电路图 Wiring Diagram

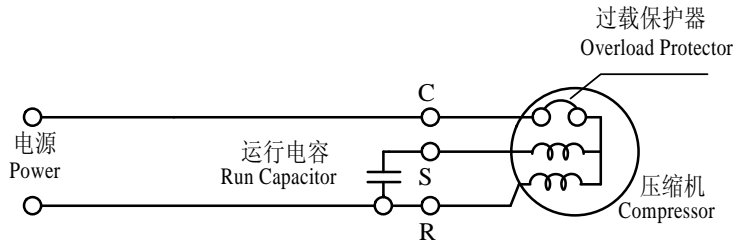

接线安装图 Electric Connecting Drawing

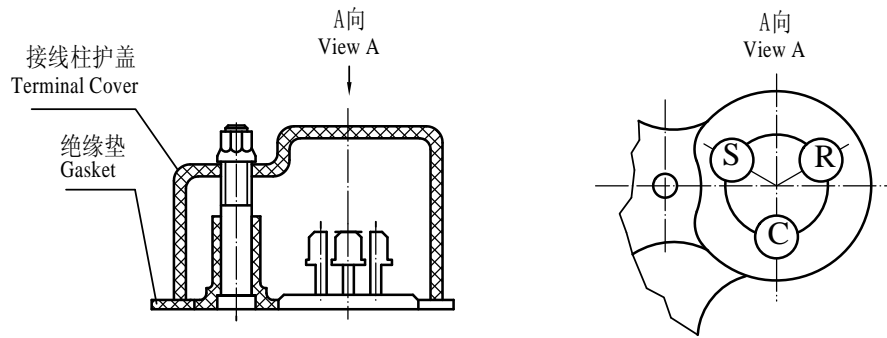

注：全金属法兰面螺母的拧紧力矩为1.0~1.5Nm  
 The tightening torque for the metallic flange nut is 1.0~1.5Nm

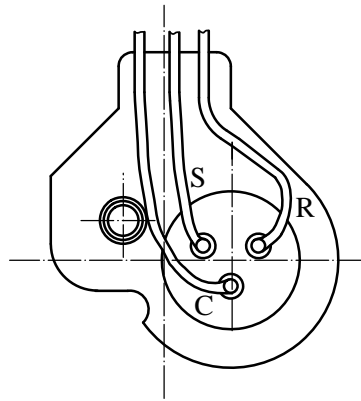

支脚安装图 Mounting Plate Installing

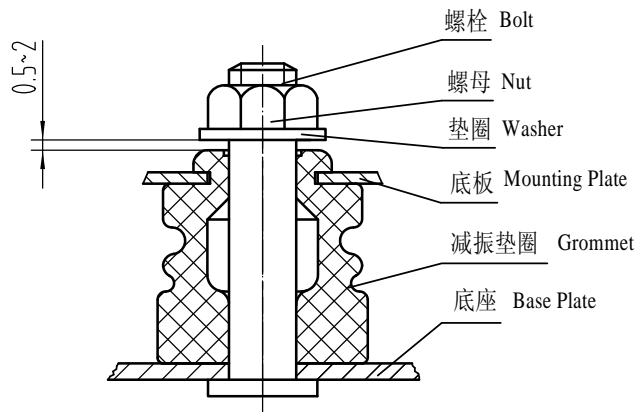

铭 牌

PAGE: 11/12

NAME PLATE

型号 (MODEL): QXA-C165rC030

QXA-DW-04



产品单元码

The code of product

质量跟踪编号

Quality tracking number

◇ 本规格书修订记录表:

标记	处数	更改文件号	签字	日期
A 版		首次发布	潘登	20101222