



SERVA-CELL[®] 2VS

High Efficiency Extended Surface Mini-Pleat Filters



Featuring Dynamic Double-V Design

- All Plastic Construction
- 100% Synthetic Media
- Fully Incinerable
- Moisture Resistant
- Chemical Resistant
- Rigid Cell Design
- Low Resistance
- Light Weight
- U.L. Class 1

SERVA-CELL® 2VS

High Efficiency Extended Surface Mini-Pleat Filters

SERVA-CELL 2VS filters offer an excellent option for applications currently using rigid cell style extended surface filters. They are a good replacement for corrugated separator style or supported pleat style rigids.

- All Plastic Construction
- 100% Synthetic Media
- Fully Incinerable
- Moisture and Chemical Resistant
- Rigid Cell Design
- Low Resistance
- Light Weight
- U.L. Class 1

SERVA-CELL 2VS filters are made with four mini-pleat media packs fashioned into two V-shaped assemblies. The inset photo shows that the end panels are made with a notch to attach the spring latch used to secure the filter in the holding frame for reverse flow installations.

All Plastic Construction – No Metal Components

SERVA-CELL 2VS filters are made from high strength, high impact polystyrene plastic. They contain no metal components. No rust, no corrosion.

100% Synthetic Media – Durable, Damage Resistant

SERVA-CELL 2VS filters are made with synthetic media. It is extremely durable, resists tearing and abrasion, and is highly damage resistant. No more media damage during shipping, handling, or installation. *This media is just plain tough.*

Fully Incinerable – Aids Disposal

All plastic components with synthetic media make SERVA-CELL 2VS filters completely incinerable. Growing restrictions on landfills in many areas make incineration the most viable disposal option.

Moisture and Chemical Resistant

High impact polystyrene plastic components and synthetic media make SERVA-CELL 2VS filters suitable for installation in systems where high moisture is present. They are also unaffected by some chemical or corrosive conditions.



Rigid Cell Design – Handles Difficult Operating Conditions

Rigid cell design mini-pleat packs, all plastic components and 100% synthetic media make SERVA-CELL 2VS filters ideal for use in the most demanding installations, including variable air volume, high air flow, turbulence, repeated fan shut down, high moisture and some chemical or corrosive conditions.

Low Resistance – Saves Energy

The Double-V design consisting of four mini-pleat media packs with glue bead separators enable SERVA-CELL 2VS filters to operate at low resistance to air flow. The wide open entrance into the filter creates a dynamically shaped air flow pattern for minimum pressure drop and maximum energy savings.

Light Weight – Saves on Shipping, Transporting

Compare the weight of SERVA-CELL 2VS filters to other high efficiency rigid filters. Less weight reduces shipping costs and simplifies transporting them to and from the plenum. Installation is also faster and easier.

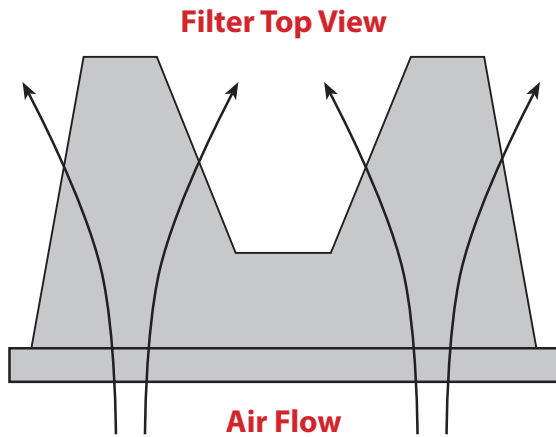

Filter Top View

Air Flow

The Double-V design creates a wide open entrance into the filter resulting in low resistance and full use of media.

Dynamic Double-V Design Creates Low Resistance

The Double-V design presents a wide open entrance into the filter allowing air to freely enter and exit at very low resistance. The mini pleat media packs are set at an angle to the direction of the incoming air to direct air flow through the pleat packs and out the back side with minimum restriction.



Economical Upgrade for Other Rigid Cell Filters

SERVA-CELL 2VS filters are an ideal upgrade for other styles of rigid cell filters, including corrugated separator style and supported pleat style. The Dynamic Double-V design provides an unbeatable combination of low resistance, high dust holding capacity and competitive price compared to these products.

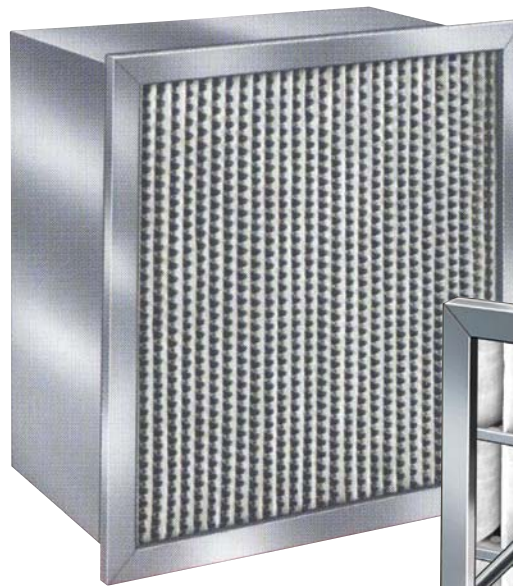

Corrugated Separator Style

Supported Pleat Style

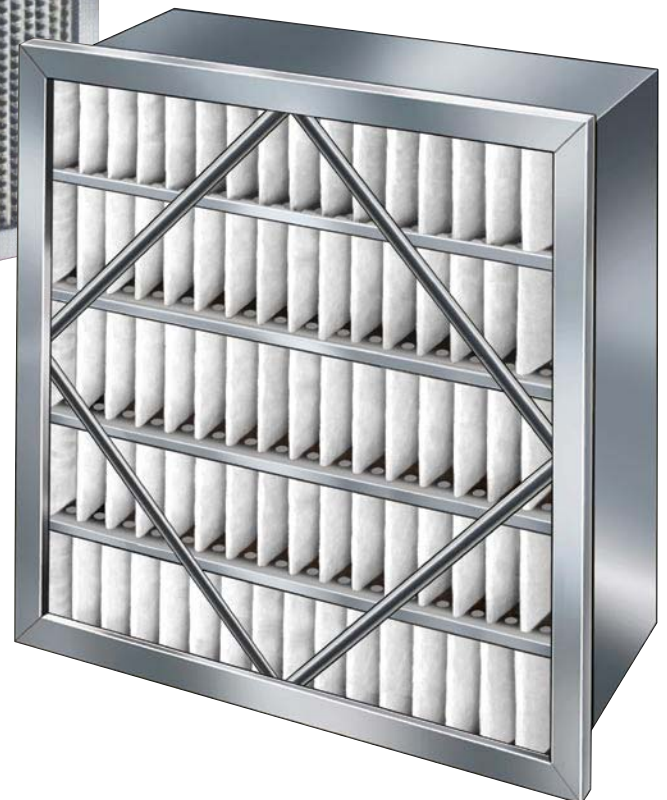

Mini-Pleat Media Packs Made with Glue Bead Separators

The media is pleated into mini-packs using continuous glue bead separators. This creates a high ration of media area to filter face area for low resistance, high dust holding capacity and long service life.

The glue bead separators bond the pleats into a highly rigid pack that maintains uniform spacing in all types of operating conditions. The pleats hold their shape and do not deform or collapse as the dirt load builds and resistance rises. Uniform pleat spacing allows dirt to load evenly over every square inch of filter surface area. The media is fully utilized with no blocking off.

If you are using other styles of rigid cell extended surface filters, compare performance and price to SERVA-CELL 2VS filters

SERVA-CELL® 2VS

High Efficiency Extended Surface Mini-Pleat Filters

Model Number	Nominal Size Inches (HxWxD)	Actual Size Inches (HxWxD)	Rated Air Flow Capacity (CFM)	Initial Resistance (In. W. G.) @Rated Air Flow	Recommended Final Resistance (In. W. G.)
MERV 14					
SL2VS95	12x24x12	11 ³ / ₈ x 23 ³ / ₈ x 11 ¹ / ₂	1000	.46"	1.5"
SL2VS95	24x24x12	23 ³ / ₈ x 23 ³ / ₈ x 11 ¹ / ₂	2000	.46"	1.5"
SL2VS95	20x24x12	19 ³ / ₈ x 23 ³ / ₈ x 11 ¹ / ₂	1650	.46"	1.5"
SL2VS95	20x20x12	19 ³ / ₈ x 19 ³ / ₈ x 11 ¹ / ₂	1400	.46"	1.5"
MERV 13					
SL2VS85	12x24x12	11 ³ / ₈ x 23 ³ / ₈ x 11 ¹ / ₂	1000	.38"	1.5"
SL2VS85	24x24x12	23 ³ / ₈ x 23 ³ / ₈ x 11 ¹ / ₂	2000	.38"	1.5"
SL2VS85	20x24x12	19 ³ / ₈ x 23 ³ / ₈ x 11 ¹ / ₂	1650	.38"	1.5"
SL2VS85	20x20x12	19 ³ / ₈ x 19 ³ / ₈ x 11 ¹ / ₂	1400	.38"	1.5"
MERV 11					
SL2VS65	12x24x12	11 ³ / ₈ x 23 ³ / ₈ x 11 ¹ / ₂	1000	.25"	1.5"
SL2VS65	24x24x12	23 ³ / ₈ x 23 ³ / ₈ x 11 ¹ / ₂	2000	.25"	1.5"
SL2VS65	20x24x12	19 ³ / ₈ x 23 ³ / ₈ x 11 ¹ / ₂	1650	.25"	1.5"
SL2VS65	20x20x12	19 ³ / ₈ x 19 ³ / ₈ x 11 ¹ / ₂	1400	.25"	1.5"

1. All performance data is based on the ASHRAE 52.2 Test Standard
2. Width and height dimensions are interchangeable. SERVA-CELL 2VS filters can be installed with the pleats vertical or horizontal
3. Continuous Operating Temperature: 140°F (60°C).

Underwriters Laboratories Inc. Classification: SERVA-CELL 2VS filters are classified Class 1 per U.L. Standard 900.

