

Installation Instructions

NOTE: Read the entire instruction manual before starting the installation.

SAFETY CONSIDERATIONS

Installing and servicing of heating and air conditioning equipment can be hazardous due to system pressures and electrical components. Only trained personnel should install or service heating and air conditioning equipment.

Untrained personnel can perform basic maintenance functions such as cleaning coils, or cleaning and replacing filters. All other operations should be performed by trained personnel. When working on heating and air conditioning equipment, observe precautions in literature, on tags, and on labels attached to the unit. Follow all safety codes. Wear safety glasses and work gloves. Have a fire extinguisher available.

Recognize safety information. This is the safety-alert symbol . When you see this symbol on the unit and in instructions or manuals, be alert to the potential for personal injury.

Understand the signal words **DANGER**, **WARNING**, and **CAUTION**. These words are used with the safety-alert symbol.

DANGER identifies the most serious hazards which **will** result in severe personal injury or death. **WARNING** signifies hazards which **could** result in personal injury or death. **CAUTION** is used to identify unsafe practices, which **may** result in minor personal injury or product and property damage. **NOTE** is used to highlight suggestions which **will** result in enhanced installation, reliability, or operation.

 **WARNING**

ELECTRICAL SHOCK HAZARD

Failure to follow this warning could result in personal injury or death.

Before beginning any installation or modification, be sure the main electrical disconnect switch(es) is in the OFF position. There may be more than one power supply. Tag the disconnect switch(es) with a suitable warning label.

Table 1 – Accessory Heater Usage

ELECTRIC HEATER PART NO.	kW	INTERNAL PROTECTION	MODEL FA, FB, PF SIZE	MODEL FC SIZE	MODEL FH SIZE	MODEL FX SIZE	MODEL FE, FK, FV, SIZE	FK, FV INTELLIGENT™ HEAT CAPABLE
1 Phase								
KFCEH0401N03	3	Non-fused	018, 024	018	001	018, 024	—	NO
KFCEH0501N05 KFCEH2401C05	5	Non-fused Circuit Breaker	018-071	018-070	001-004	018-060	001-006	NO NO
KFCEH0801N08 KFCEH2501C08	8	Non-fused Circuit Breaker	018-071	018-070	001-004	018-060	001-006	NO NO
KFCEH2901N09	9*	Non-fused	036-071	036-070	002-004	036-060	003-006	YES†
KFCEH0901N10 KFCEH2601C10	10	Non-fused Circuit Breaker	018-071	018-070	001-004	018-060	001-006	NO NO
KFCEH3001F15 KFCEH2701C15 KFCEH3101C15	15	Fused Circuit Breaker Circuit Breaker	024-071	024-070	001-004	024-060	001-006	YES† YES† YES†
KFCEH3201F20 KFCEH2801C20 KFCEH3301C20	20	Fused Circuit Breaker Circuit Breaker	030-071	030-070	002-004	030-060	001-006	YES† YES† YES†
3 Phase Only								
KFCEH1601315	15	Non-fused	036-071	036-070	002-004	036-060	001-006	NO
KFCEH2001318	18	Non-fused	042-071	042-070	003, 004	042-060	003-006	NO
3 Phase, Factory Shipped‡								
KFCEH3401F24 KFCEH3501F30	24 30	Fused Fused	048-071	048-070	003, 004	048-060	005, 006	YES† YES†

* Field convertible to 3 phase.

† These heaters are Intelligent Heat capable when used with the FK and FV fan coils and incorporate 2-speed programmable Thermidstat™ control (Tx-xRH), capable zoning system, or an FE fan coil and Infinity™/Evolution™ Control.

‡ Field convertible to 1 phase, single or multiple supply circuit.

Table 2 – Minimum CFM and Motor Speed Selection

FAN COIL FA, FB, FC, FH, FX, PF SIZES	HEATER kW									
	3	5	8	9	10	15	18	20	24	30
018	525	525	525	—	600*	—	—	—	—	—
024	700	700	700	700	700	775*	—	—	—	—
030, 033	—	875	875	875	875	875	—	1060*	—	—
036, 038,	—	1050	970	970	970	920	—	1040	—	—
042	—	1225	1225	1225	1225	1225	1225	1225	—	—
048, 054,	—	1400	1400	1400	1400	1400	1400	1400	1400	1400
060, 070,	—	1750	1750	1750	1750	1750	1750	1750	1750	1750

* Indicates medium speed (blue). All other motor speeds at low tap.

This instruction describes the installation of Part No. KFCEH accessory heaters in FA, FB, FC, FE, FH, FK, FV, FX and PF fan coils.

NOTE: Electric heaters require a minimum airflow. Minimum airflow and motor speed selection are listed in Table 2. For 3-through 18-kW standard heaters, there are no clearance requirements for the first 36 in. (914 mm) of ductwork. For 20-through 30-kW heaters, a 1-in. (25 mm) clearance is required for the first 36 in. (914 mm) of ductwork.

INSTALLATION

Procedure 1 — Install Electric Heater Assembly

NOTE: Ensure heater coils are not deformed or damaged during heater installation.

1. Make sure power to unit is off.
2. Remove blower access panel of fan coil unit.

⚠ CAUTION

ELECTRICAL OPERATION HAZARD

Failure to follow this caution may result in equipment damage or improper operation.

Before installation of heater, the black and yellow pigtail leads must be removed from the fan coil PCB or wire harness to prevent possible damage to the product. Electrical power will be provided to the board through the heater circuit plug.

3. Disconnect 2 power wires (black and yellow pigtail leads) from PCB or wire harness (if applicable) and discard. Wires may be part of a plug assembly or attached to terminals L1 and L2. Remove cooling control plate from fan coil (if equipped). For 18-, 24-, and 30-kW heaters, remove adapter plate. (See Fig. 1.)
4. Insert heater assembly into front of fan coil so that element rods engage holes in rear heat shield.
5. Attach heater control plate to fan coil using 2 screws provided. For 18-, 24-, and 30-kW heater models, attach front of heater to fan deck using third screw. (See Fig. 1.)

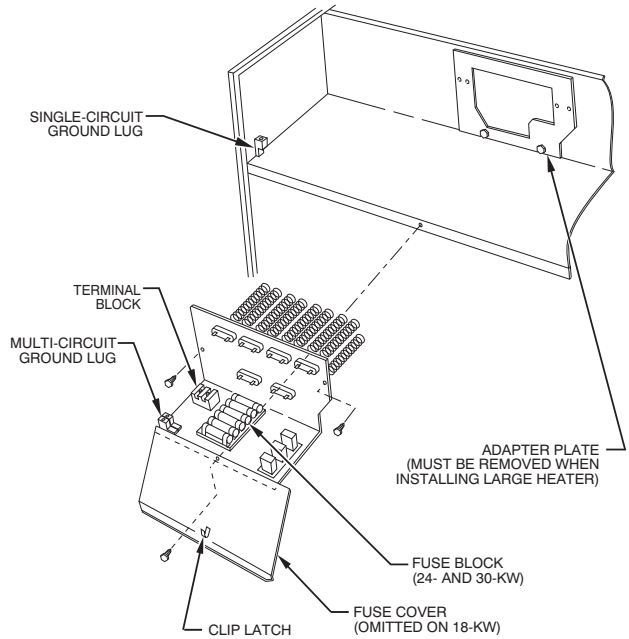

A90154

Fig. 1 - Installation of 18-, 24-, and 30-kW Model Heaters

Procedure 2 — Attach Fuse Box or Circuit Breaker Box

1. For 15- and 20-kW fused models:
After installing heater assembly, attach fuse assembly to side of fan coil unit by inserting fuse box tab between insulation and to left side of unit and fan deck. Mount front of assembly to side flange with 2 screws provided. On fan coil units size 042 and larger, remove wire tie that shortens wire length between heater and fuses. Fuse cover is closed by engaging dimples in fuse box. (See Fig. 2.)
2. For 24- and 30-kW fused models:
Fuse assembly is mounted on heater. Be sure fuse cover is closed by engaging clip latch on unit top panel. (See Fig. 1.)

⚠ WARNING

ELECTRICAL SHOCK HAZARD

Failure to follow this warning could result in personal injury or death.

Ensure fuse box is closed before power is turned to ON position. There may be more than one power supply.

KFCEH

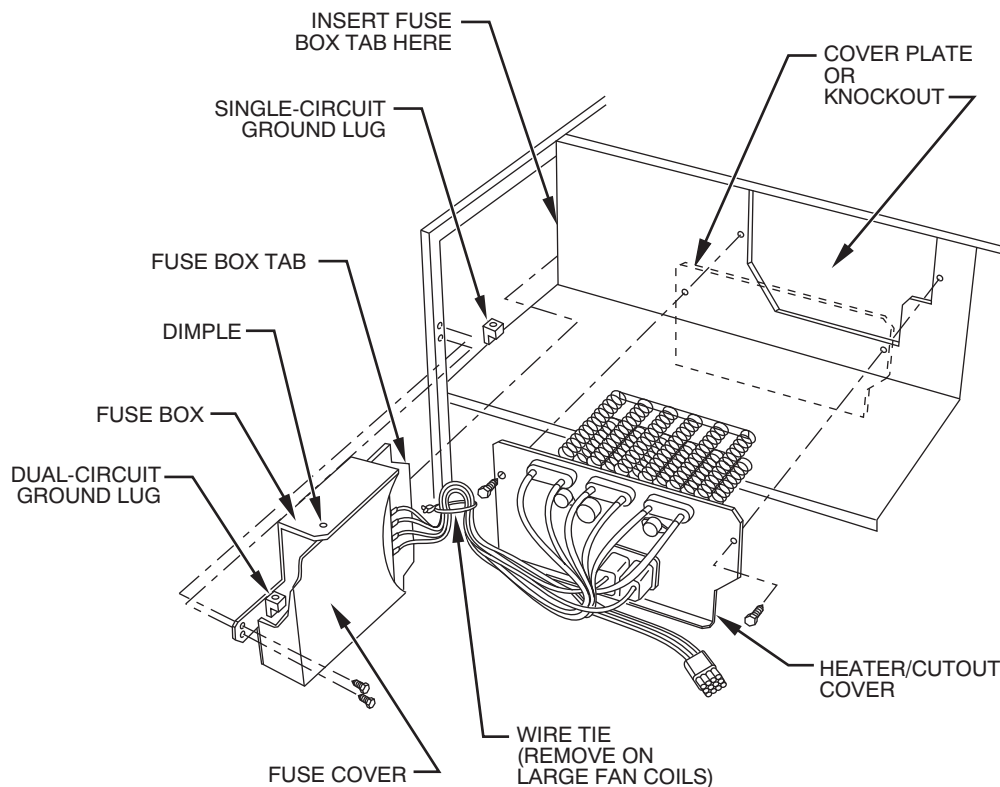

Fig. 2 - Installation of Fused Model Heater

A90151

3. For 5- through 20-kW circuit breaker models:
After installing heater assembly, attach circuit breaker assembly to unit with screws provided. (See Fig. 3.) On fan coil units size 042 and larger, remove wire tie that shortens wire length between heater and circuit breaker assembly to allow mounting of circuit breaker assembly. (See Fig. 3.)
4. Circuit breaker models require installing a window bezel in unit door to provide safe access to circuit breakers. The window bezel mounts on the outside of the blower door. (See Fig. 4.)
 - a. Cut insulation away from rectangular access hole in blower access panel.
 - b. Remove adhesive backing from window bezel and from the outside. Insert the window through the rectangular hole and seat firmly on the door surface. Press firmly in place to seat the adhesive. (See Fig. 4.)

Procedure 3 — Electrical Connections

Refer to unit instructions for recommended wiring procedures. Install wiring in accordance with all applicable local and national codes. (See Tables 3 and 4.) Connect heater wiring harness plug to receptacle on PCB or wire harness. A positive connection must be made between plug and receptacle. Plug will interlock with receptacle when properly seated. Harness contains both 24-v control and high-voltage wiring. Blower power is provided through heater harness.

NOTE: Units with or without electric heaters require a minimum CFM. Refer to unit wiring label to ensure the fan speed selected with electric heaters is equal to or greater than the minimum fan speed indicated. The minimum CFM for cooling is determined by the outdoor unit requirements. Use the higher of the 2 for year-round operation.

A. Wire 24-v Control Systems

1. Connections to unit
Use No. 18 AWG color-coded, insulated (35°C minimum) wire to make low-voltage connections between thermostat, fan coil unit, and outdoor unit. If thermostat is located more than 100 ft (20 m) from unit (as measured along the low-voltage wire), use No. 16 AWG color-coded, insulated (35°C minimum) wire. All wiring must be separated from line voltage power leads. Refer to outdoor unit wiring instructions for additional wiring procedure recommendations.
2. Transformer
Transformer is factory wired for 230-v operation. For 208-v applications, disconnect black wire on transformer 230-v terminal and reconnect it to 208-v terminal. (See Fig. 5.) The secondary circuit of transformer is protected by a 5-amp fuse mounted on PCB.

⚠ CAUTION

ELECTRICAL OPERATION HAZARD

Failure to follow this caution may result in product damage or improper operation.

On FA, FB, FC, FH, FX, or PF if W2, W3, and E are individually connected on any 3 stage heater (18, 20, 24, 30 kW), as with outdoor thermostats or any other situation, an emergency heat relay must be used. This relay is in kit Part No. KHAOT0201SEC and is normally used with kit Part No. KHAOT0301FST for 2 outdoor thermostat systems.

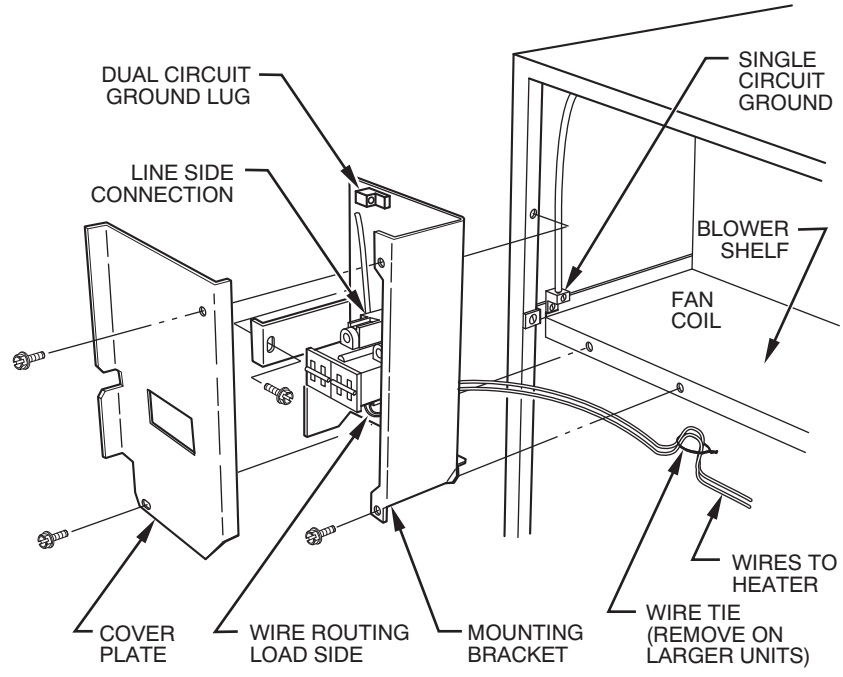

Fig. 3 - Installation of Circuit Breaker Model Heater

A90153

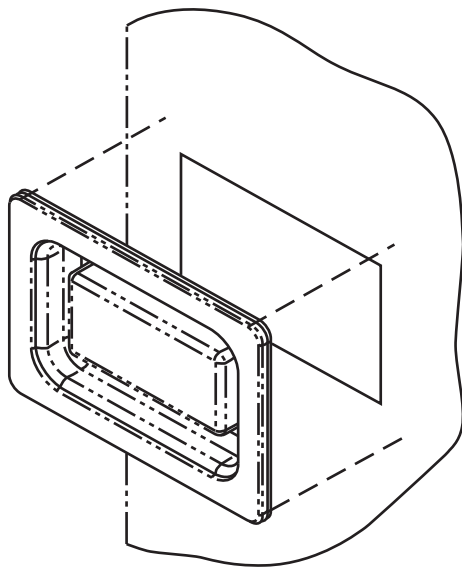

Fig. 4 - Installation of Window Bezel for Circuit Breaker Model Heater

A03069

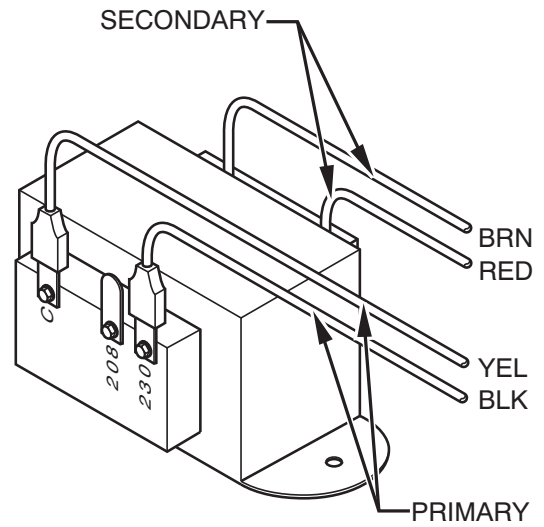

Fig. 5 - Connection of Transformer

A94067

Table 3 – Electric Heater Electrical Data

HEATER PART NO.	kW		INTERNAL CIRCUIT PROTECTION	HEATER AMPS 208/230v			MIN AMPACITY 208/230v*			Min Wire Size (AWG) 208/230v††			BRANCH CIRCUIT			Max Fuse/CH Bkr Amps 208/230v			Max Wire Length 208/230v (F)‡‡		
	240v	208v		P H A S E	Single Circuit	Dual Circuit		Single Circuit	Dual Circuit		Single Circuit	Dual Circuit		Single Circuit	Dual Circuit		Single Circuit	Dual Circuit			
						L1,L2	L3,L4		L1,L2	L3,L4		L1,L2	L3,L4		L1,L2	L3,L4		L1,L2	L3,L4	L1,L2	L3,L4
KFCEH0401N03	3	2.3	1	None	10.9/12.0	—	—	15.9/17.3	—	—	12/12	—	—	20/20	—	—	67/68	—	—	—	—
KFCEH0501N05†	5	3.8	1	None	18.1/20.0	—	—	26.0/28.4	—	—	10/10	—	—	30/30	—	—	66/66	—	—	—	—
KFCEH0501N05‡	5	3.8	1	None	18.1/20.0	—	—	31.2/33.5	—	—	8/8	—	—	35/35	—	—	85/88	—	—	—	—
KFCEH2401C05‡	5	3.8	1	Ckt Bkr	18.1/20.0	—	—	31.2/33.5	—	—	8/8	—	—	35/35	—	—	85/88	—	—	—	—
KFCEH2401N08	8	6.0	1	None	28.9/32.0	—	—	44.7/48.5	—	—	10/10	—	—	45/50	—	—	59/60	—	—	—	—
KFCEH2501C08	8	6.0	1	Ckt Bkr	28.9/32.0	—	—	44.7/48.5	—	—	10/10	—	—	45/50	—	—	59/60	—	—	—	—
KFCEH2901N03**	9	6.8	1	None	32.8/36.0	—	—	49.5/53.5	—	—	8/8	—	—	50/60	—	—	54/87	—	—	—	—
KFCEH2901N03‡	9	6.8	3	None	18.8/20.8	—	—	32.0/34.5	—	—	8/8	—	—	35/35	—	—	83/85	—	—	—	—
KFCEH0901N10	10	7.5	1	None	36.2/40.0	—	—	53.8/58.5	—	—	6/6	—	—	60/60	—	—	78/80	—	—	—	—
KFCEH2601C10	10	7.5	1	Ckt Bkr	36.2/40.0	—	—	53.8/58.5	—	—	6/6	—	—	60/60	—	—	78/80	—	—	—	—
KFCEH3001F15**	15	11.3	1	Fuse	54.2/59.9	36.2/40.0	18.1/20.0	76.3/83.4	53.8/58.5	22.7/25.0	4/4	6/6	10/10	80/90	60/60	25/25	88/89	78/80	75/76	75/76	75/76
KFCEH2701C15**	15	11.3	1	Ckt Bkr	—	36.2/40.0	18.1/20.0	—	53.8/58.5	22.7/25.0	—	6/6	10/10	—	—	—	—	—	—	—	—
KFCEH3101C15**	15	11.3	3	None	31.3/34.6	—	—	47.7/51.8	—	—	8/8	—	—	50/60	—	—	56/90	—	—	—	—
KFCEH2001F18	18	13.5	3	None	37.6/41.5	—	—	55.5/60.4	—	—	6/6	—	—	60/70	—	—	76/77	—	—	—	—
KFCEH3201F20**	20	15.0	1	Fuse	72.3/79.9	36.2/40.0	36.2/40.0	98.9/108.4	53.8/58.5	45.3/50.0	3/2	6/6	8/8	100/110	60/60	50/50	85/109	78/80	59/59	59/59	59/59
KFCEH2801C20**	20	15.0	1	Ckt Bkr	—	36.2/40.0	36.2/40.0	—	53.8/58.5	45.3/50.0	—	6/6	8/8	—	—	—	—	—	—	—	—
KFCEH3301C20**	20	15.0	1	Ckt Bkr	—	36.2/40.0	36.2/40.0	—	53.8/58.5	45.3/50.0	—	6/6	8/8	—	—	—	—	—	—	—	—
KFCEH3401F24††	24	18.0	3	Fuse	50.1/55.4	—	—	71.2/77.8	—	—	4/4	—	—	80/80	—	—	94/95	—	—	—	—
KFCEH3501F30††	24	18.0	1	Fuse	86.7/95.5	—	—	116.9/127.9	—	—	1/1	—	—	125/150	—	—	115/116	—	—	—	—
KFCEH3501F30††	30	22.5	3	Fuse	62.6/69.2	—	—	86.8/95.0	—	—	3/3	—	—	90/100	—	—	97/98	—	—	—	—
KFCEH3501F30††	30	22.5	1	Fuse	109.0/120.0	—	—	144.8/158.5	—	—	0/00	—	—	150/175	—	—	117/150	—	—	—	—

Table 4 – Field Multipoint Wiring or 24- and 30-kW Single Phase

HEATER PART NO.	kW	P H A S E	HEATER AMPS 208/230v			MIN AMPACITY 208/230v*			MIN WIRE SIZE (AWG) 208/230v††			MIN GND WIRE SIZE 208/230v			MAX FUSE/CKT BKR AMPS 208/230v			MAX WIRE LENGTH 208/230v (F)‡‡		
			240v	208v	L1,L2	L3,L4	L5,L6	L1,L2	L3,L4	L5,L6	L1,L2	L3,L4	L5,L6	L1,L2	L3,L4	L5,L6	L1,L2	L3,L4	L5,L6	
																				L1,L2
KFCEH3401F24†	24	18.0	1	28.9/32.0	28.9/32.0	28.9/32.0	44.7/48.5	36.2/40.0	36.2/40.0	8/8	8/8	8/8	10/10	45/50	40/40	40/40	59/60	73/73	73/73	59/59
KFCEH3501F30†	30	22.5	1	36.2/40.0	36.2/40.0	36.2/40.0	53.8/58.5	45.3/50.0	45.3/50.0	6/6	8/8	8/8	10/10	60/60	50/50	50/50	78/80	59/59	59/59	59/59

* Includes blower motor amps of largest fan coil used with heater.

† Field convertible to 1 phase, single or multiple supply circuit.

‡ Field convertible to 3 phase.

** Heaters are Intelligent Heat™ capable when used with the FK and FV fan coils and corporate Thermidstat™ control (Tx-xRH), or FE fan coil and Infinity™/Evolution™ Control.

†† Copper wire must be used. If other than uncoated (non-plated), 75°C ambient, copper wire (solid wire for 10 AWG and smaller, stranded wire for larger than 10 AWG) is used, consult applicable tables of the National Electric Code (ANSI/NFPA 70).

‡‡ Length shown is as measured 1 way along wire path between unit and service panel for a voltage drop not to exceed 2%.

NOTES:

1. For fan coil sizes 018-036.
2. For fan coil sizes 042-060 and all FE, FK, and FV sizes.
3. Single circuit application of F15 and F20 heaters requires single-point wiring kit accessory.



3. Heater staging

The units are shipped circuited for single-stage operation. Use outdoor thermostat kit Part No. KHAOT0301FST for 2-stage operation. Use both kit Part No. KHAOT0201SEC and KHAOT0301FST for 3-stage operation. When 2-stages are desired, cut W3 at the W2 wire nut, strip, and reconnect per wiring staging layout in Installation Instructions for fan coils.

 - a. The 3-, 5-, 8-, and 10-kW heaters are single stage only.
 - b. The 9- and 15-kW heaters are adaptable for 2-stage operation.
 - c. The 18-, 20-, 24-, and 30-kW heaters are adaptable for 3-stage operation.

4. Intelligent Heat™ Staging

FK and FV Fan Coils are capable of Intelligent Heat™ staging when installed with capable electric heaters (see Table 1) and a corporate Thermidistat™ control (Tx-xRH), or Comfort Zone II™ /Zone Perfect Plus™. An FE fan coil plus Infinity™ /Evolution™ Control combination is also capable of Intelligent™ heat staging. Consult the fan coil Installation and Start-up Instructions for wiring details. Do not install with outdoor thermostats when installing for Intelligent Heat™ Staging.

5. Rectifier and Time Delay Boards

Each heater element is controlled by a relay mounted on the heater panel. The relay has a 24v DC coil. Each relay has a small rectifier board attached directly to relay coil terminals. The rectifier board converts incoming 24v AC control signal to DC. Some heaters may have up to three relays. The second and/or third relay rectifier board also has a time delay feature and a small jumper wire built into it. With the jumper uncut, the time delay allows the second stage heat to be energized approximately 5 sec after the first stage. On 18-, 24-, and 30-kW heaters, the third stage relay board jumper is cut at factory. This provides an 8 sec delay after first stage relay closes.

B. Power Connections

NOTE: Heater supply circuit wire size and overcurrent protection must comply with National Electrical Code (NEC) and UL branch circuit requirements. (See Table 3 and 4.) Wires and overcurrent protection, integral to the heater, are not required to meet branch circuit requirements. **Internal circuit protection of 60 amps (maximum) is acceptable.**

1. Unprotected heaters: (See Fig. 6, 10, and 11.)
 - a. The 5- through 10-kW single-phase and 15- and 18-kW 3-phase heaters can be wired for single-supply circuit only. Supply circuit connects to heater pigtail leads (terminal block on 18-kW heaters).
 - b. The 3- through 10-kW single-phase heaters can use a separate field-installed, factory-authorized disconnect kit which installs in fan coil.

NOTE: Refer to wiring label for component locations.

- c. The 9-kW heater is factory wired for single supply circuit, single phase. To convert heater to single supply circuit, 3 phase:
 - (1.) Disconnect blue wire from limit switch (LS3). Cut, strip, and connect to field wire L3.
 - (2.) Disconnect yellow wire from LS1 and connect to LS3.
 - (3.) Disconnect blue wire from relay 2 terminal 2 and connect to LS1.

2. Circuit breaker heaters: (See Fig. 7 and 9.)

- a. The 3- through 10-kW heaters can be wired for single-supply circuit only.
 - b. The 15- and 20-kW heaters can be wired for dual-supply circuits only.
3. Fused heaters: (See Fig. 8, 12, 13, and 14.)
 - a. The 15- and 20-kW heaters can be wired for single- or dual-supply circuits. Single-supply circuit wiring requires a factory-authorized, single-point adapter kit.
 - b. The 24- and 30-kW heaters can be wired for single- or multiple-supply circuits. Heaters are factory wired for single circuit 3 phase. To convert heaters to single circuit single phase, disconnect yellow lead from L3 and connect to L1. Disconnect black lead from L3 and connect to L2. To convert heaters to multiple-supply circuit single phase, remove and discard leads between single-circuit terminal block and fuse block. Remove and discard single-circuit terminal block. Attach L1 through L6 power leads as indicated on label next to fuse block.

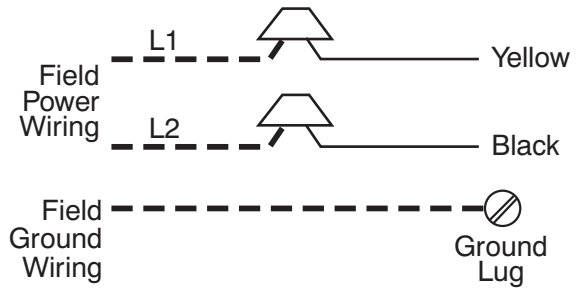

Fig. 6 - 3, 5, 8, 9 10 kW Non-fused Heaters (9 kW is field convertible to 3-phase. See Procedure 3. B. 1. c.)

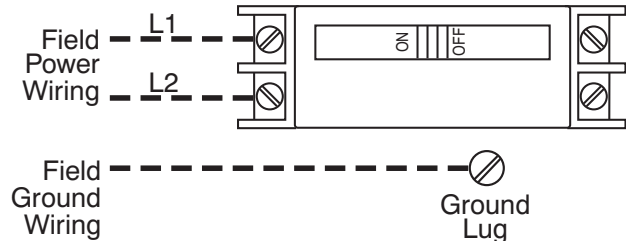

Fig. 7 - 5, 8 10 kW Circuit Breaker and Disconnect Heaters

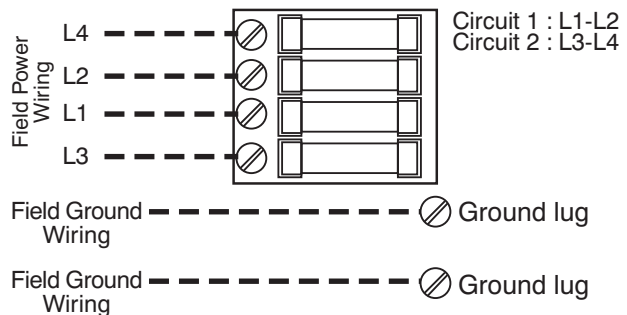

Fig. 8 - 15 and 20 kW Fused Heaters (15 and 20 kW fused heaters are factory wired for dual supply circuits. Single supply circuit is possible with approved single point wiring kit.)

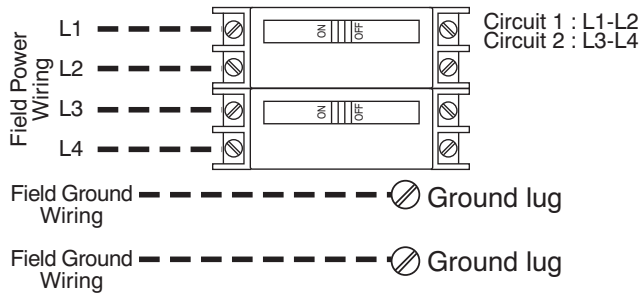
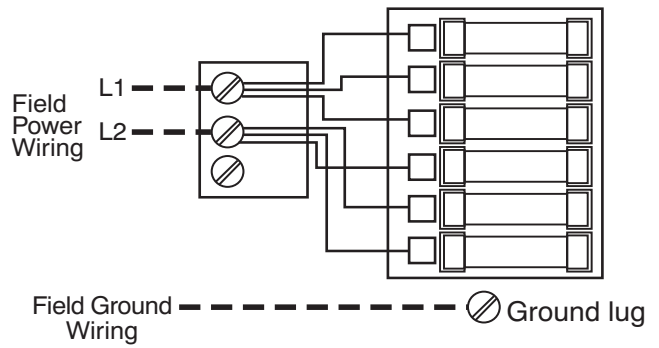

Fig. 9 - 15 and 20 kW Circuit Breaker Heaters

A00079



**Fig. 13 - 24 and 30 kW Heaters
(Single Phase, Single Supply Circuit-Field Modified)**

A00083

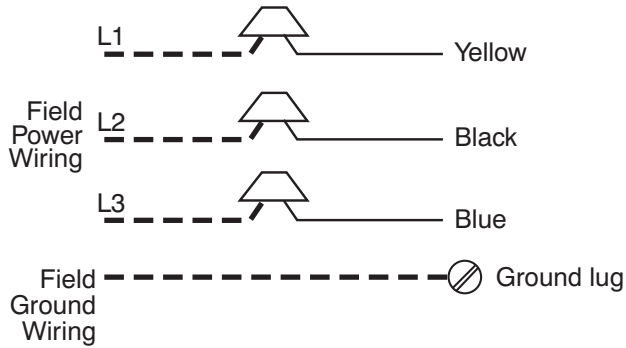

Fig. 10 - 15 kW 3-Phase Heater

A00080

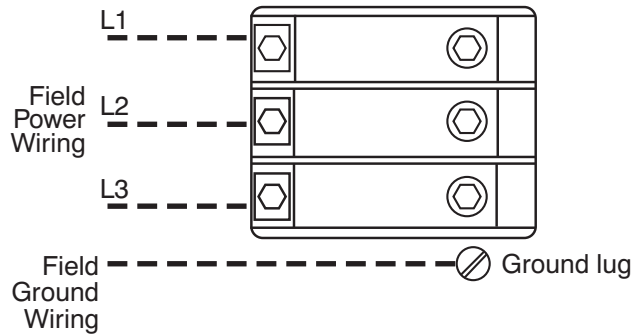

Fig. 11 - 18 kW 3-Phase Heater

A00081

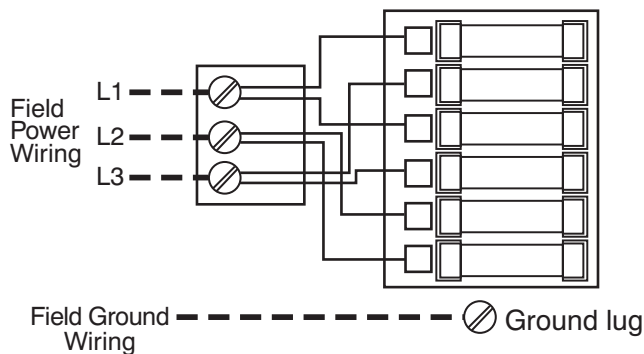
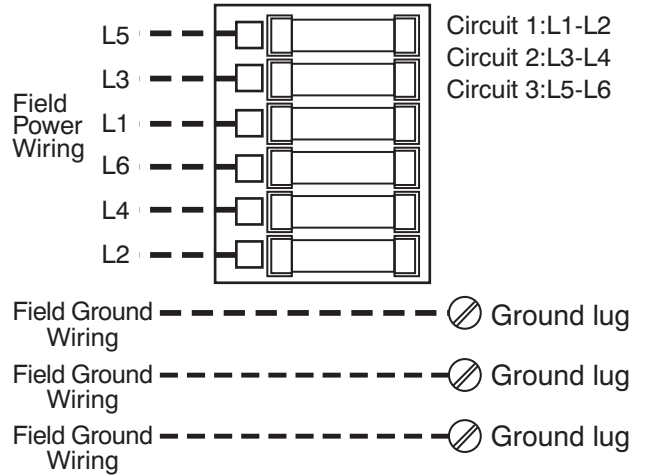

Fig. 12 - 24 and 30 kW Heaters (3-Phase Wiring Factory Supplied)

A00082



**Fig. 14 - 24 and 30 kW Heaters
(Single Phase, Multiple Supply Circuits-Field Modified)**

A00084

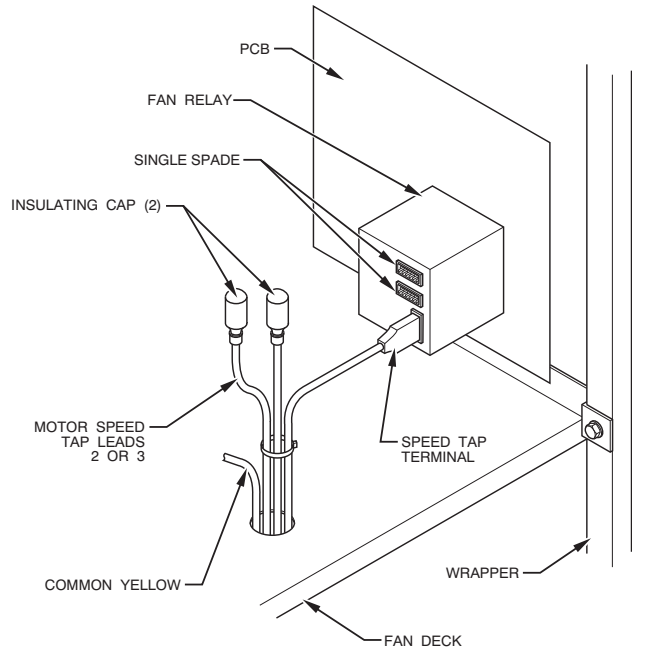

Fig. 15 - PSC Motor Speed Tap and Fan Relay

A94068

KFC EH

KFCEH

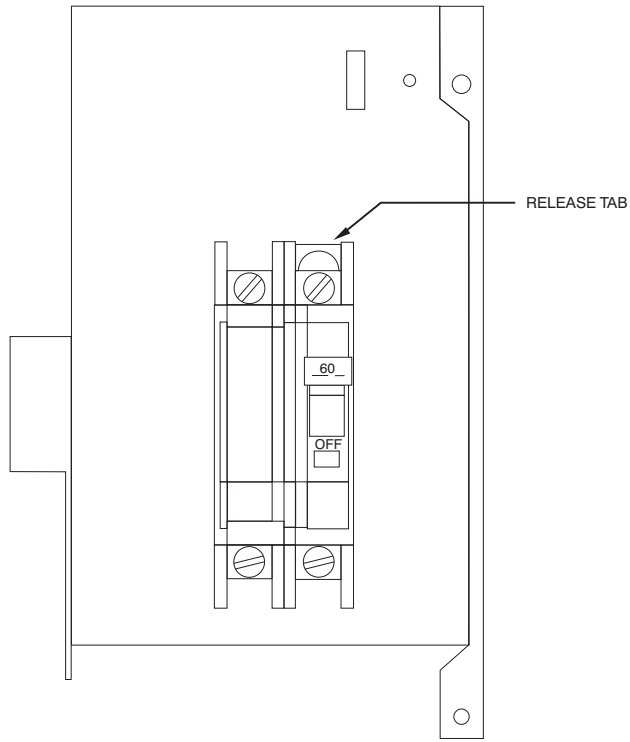

Fig. 16 - Conversion of Circuit Breaker

A99094

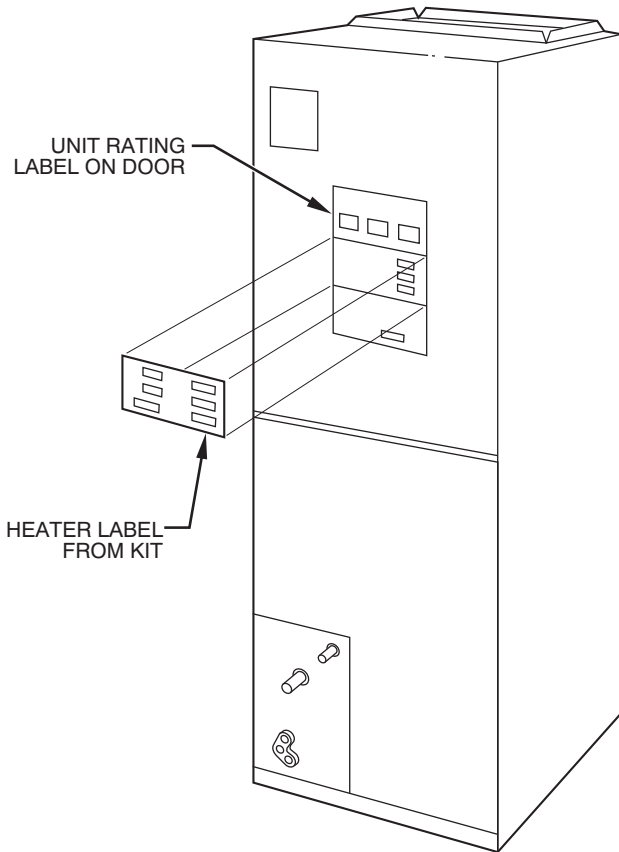

Fig. 17 - Heater Rating Label Location

A96251

C. Ground Connections

⚠ WARNING

ELECTRICAL SHOCK HAZARD

Failure to follow this warning could result in personal injury or death.

According to NEC, ANSI/NFPA 70, and local codes, cabinet must have an uninterrupted or unbroken ground to minimize personal injury if an electrical fault should occur. The ground may consist of electrical wire or metal conduit when installed in accordance with existing electrical codes. (See Ground/Conduit Note below.)

NOTE: Use UL-listed conduit and conduit connector for connecting supply wire(s) to unit to obtain proper grounding. If conduit connection uses reducing washers, a separate ground wire must be used. Grounding may also be accomplished by using grounding lugs provided in control box.

1. For unprotected or single-circuit heaters, 1 equipment ground connection is provided on fan coil unit. (See Fig. 1 or 2.)
2. For 15- and 20-kW circuit breaker heaters, an additional ground lug is provided on circuit breaker mounting bracket for dual-circuit grounding. (See Fig. 3.)
3. For 15- and 20-kW fused heaters, an additional ground lug is provided on fuse mounting bracket for dual-circuit grounding. (See Fig. 2.)
4. For 24- and 30-kW fused heaters, 2 additional ground lugs are provided for single-phase, multicircuit wiring. (See Fig. 1.)

D. Fan Speeds for FA(A,B,C) FB, FC4(B,C), FH, FX(A,B), FY, PF with PSC motors

1. Speed tap selection is done at fan relay. To change motor speeds, disconnect fan lead on relay and replace with motor speed tap desired. Save insulating cap and place on motor lead that was removed from relay. (See Fig. 15.) Refer to Table 5 for further clarification of speed tap selections.

Table 5 – Color Code for Motor Lead Wires FA, FB, FC4(B,C), FH, FX4(A,B), PF with PSC motors

MOTOR SPEED TAP	WIRE COLOR
Common	Yellow
High	Black
Medium	Blue (Factory selected)
Low	Red (Blue on 2-speed models)

E. FK, FE, FV

1. Refer to Table 6 thru 8 for minimum CFM and airflow delivery.

F. FC4D, FX4C, and PF with X13 motors

1. Speed tap selection is done at motor terminals. To change motor speed, disconnect motor lead on terminal 2 (medium) and move to either terminal 1 (low) or 3 (high).

Procedure 4 — Conversion of Circuit Breaker for Downflow Applications

1. Tag and disconnect factory wiring from terminals on circuit breaker(s).
2. Pull white plastic release tab on the bottom of circuit breaker straight out to release circuit breaker from bracket. (See Fig. 16.)
3. Remove quick connect adapters from factory side of breaker(s). Reinstall adapters on other end of breakers(s). Be sure

adapter is located between lug screw and plate. Torque lug screw to 30-in.-lb.

4. Rotate breaker 180° from its original position and reinstall in bracket. Slide breaker slot into sheet metal tab and snap breaker into place. Make sure both tabs engage breaker. Reconnect wiring on opposite end. Make sure wires are positioned as before.
5. Remount circuit breaker bracket into unit so that the switch will be in UP position when ON.

Procedure 5 — Attach Wiring Diagram and Rating Label

Attach heater rating label included with kit over existing electrical information label located on front access panel of fan coil. (See

Fig. 17.) If kit contains multiple rating labels, ensure correct label is applied (check phase and supply circuits). Affix wiring diagram label 3, included with kit, on blower housing above fan coil wiring label. Do not cover up existing wiring label.

NOTE: The fact there is a label 3 does not imply there should be label 1 or 2. These kits have only one wiring label - label 3.

Procedure 6 — Verify Installation

After completion of heater installation, check wiring to ensure tightness and that proper connections and routings have been made. Ensure all electrical covers are in place and proper labels have been applied. Reinstall blower access panel before turning unit power on.

Table 6 – FK, FV, Airflow Delivery (CFM) - Electric Heating Modes

FAN UNIT SIZE	OUTDOOR UNIT CAPACITY BTUH	ELECTRIC HEATER kW RANGE											
		0—5			0—10			0—15			0—20		
		LO	NOM	HI	LO	NOM	HI	LO	NOM	HI	LO	NOM	HI
001 002	18,000	625	625	625	675	675	675	*	*	*	*	*	*
	24,000	650	725	835	*	725	835	875	875	875	*	*	*
	30,000	815	905	1040	*	905	1040	900	900	1040	1100	1100	1100
	36,000	980	1085	1250	980	1085	1250	980	1085	1250	1100	1100	1250
003	24,000	675	725	835	875	875	875	*	*	*	*	*	*
	30,000	815	905	1040	875	905	1040	1100	1100	1100	*	*	*
	36,000	980	1085	1250	980	1085	1250	1100	1100	1250	1225	1225	1250
	42,000	1140	1270	1460	1140	1270	1460	1140	1270	1460	1225	1270	1460
FAN UNIT SIZE	OUTDOOR UNIT CAPACITY BTUH	ELECTRIC HEATER kW RANGE											
		0—10			0—15			0—20			0—30		
		LO	NOM	HI	LO	NOM	HI	LO	NOM	HI	LO	NOM	HI
005	30,000	975	975	1040	1100	1100	1100	*	*	*	*	*	*
	36,000	980	1085	1250	1100	1100	1250	1250	1250	1250	*	*	*
	42,000	1140	1270	1460	1140	1270	1460	1250	1270	1460	1500	1500	1500
	48,000	1305	1450	1665	1305	1450	1665	1305	1450	1665	1500	1500	1665
006	36,000	1100	1100	1250	1350	1350	1350	*	*	*	*	*	*
	42,000	1140	1270	1460	1350	1350	1460	1525	1525	1525	*	*	*
	48,000	1305	1450	1665	1350	1450	1665	1525	1525	1665	1750	1750	1750
	60,000	1630	1810	2085	1630	1810	2085	1630	1810	2085	1750	1810	2085

*Airflow not recommended for heater/system size.

NOTE: LO, NOM, and HI refer to AC/HP CFM ADJUST selection.

KFCFH

Table 7 – FK, FV, Minimum CFM for Electric Heater Application (CFM) - Electric Heating Modes

FAN COIL UNIT	HEAT PUMP UNIT SIZE	CFM				
		HEATER SIZE kW				
		5	8, 9, 10	15	18, 20	24, 30
001 002	Heater Only	625	625	725	875	—
	018	625	625	—	—	—
	024	650	725	875	—	—
	030	800	875	875	1040	—
	036	970	970	970	1040	—
003	Heater Only	675	700	850	1050	—
	024	675	875	875	—	—
	030	800	875	1100	1150	—
	036	975	975	1100	1225	—
	042	1125	1125	1125	1225	—
005	Heater Only	675	700	850	1050	1400
	030	800	875	875	1150	—
	036	975	975	1100	1225	—
	042	1125	1125	1125	1225	—
	048	1305	1305	1305	1305	1400
006	Heater Only	1050	1050	1050	1050	1750
	036	1100	1100	1350	1350	—
	042	1125	1125	1350	1350	—
	048	1300	1300	1350	1465	1750
	060	1625	1625	1625	1750	1750

NOTES:

1. Heater Only—Air conditioner with electric heater application.
2. These airflows are minimum acceptable airflows as UL listed. Actual airflow delivered will be per airflow delivery chart for Electric Heating Modes.

Table 8 – FE4A/FE5A Fan Coil Airflow Delivery Chart (CFM) — Electric Heating Modes

MODEL FE4A	OUTDOOR UNIT CAPACITY BTUH	ELECTRIC HEATER kW RANGE						
		5	9	10	15	20	24	30
002	EMERGENCY	625	625	675	775	950	—	—
	18,000	625	625	675	—	—	—	—
	24,000	650	725	775	900	—	—	—
	30,000	800	875	875	925	1125	—	—
	36,000	975	975	975	1025	1125	—	—
003	EMERGENCY	675	700	775	850	1050	—	—
	24,000	675	875	875	1100	1150	—	—
	30,000	800	875	875	1100	1150	—	—
	36,000	975	975	1025	1150	1250	—	—
	42,000	1125	1125	1125	1150	1350	—	—
005	EMERGENCY	675	700	775	850	1050	1400	1425
	30,000	800	875	875	1100	1150	—	—
	36,000	975	975	1025	1150	1250	—	—
	42,000	1125	1125	1125	1150	1250	—	—
	48,000	1305	1305	1305	1305	1350	1500	1600
006	EMERGENCY	1050	1050	1050	1050	1125	1750	1750
	36,000	1050	1050	1100	1350	1350	—	—
	42,000	1125	1125	1150	1350	1350	—	—
	48,000	1300	1300	1300	1350	1500	1750	1750
	60,000	1625	1625	1625	1625	1750	1750	1750
MODEL FE5A	OUTDOOR UNIT CAPACITY BTUH	ELECTRIC HEATER kW RANGE						
		5	9	10	15	20	24	30
004	EMERGENCY	675	775	775	900	1125	—	—
	24,000	975	975	975	—	—	—	—
	30,000	1050	1050	1100	1125	—	—	—
	36,000	1050	1050	1100	1350	1350	—	—
	42,000	1125	1125	1150	1350	1350	—	—

NOTES:

1. Emergency – Air conditioner with electric heater application, or emergency heat.
2. These airflows are minimum airflows as UL listed.
3. Dashed entry indicates that the heater/fan coil/outdoor unit combination is not approved. Do not apply.

KFCEH