



### STANDARD CONSTRUCTION

MATERIAL:  
24 GAUGE ASTM A-653 HOT-DIPPED GALVANIZED STEEL SHEET

STANDARD SIZES:

MODEL	WIDTH	LENGTH	HEIGHT
DPG2644	26"	44"	2"
DPG2648	26"	48"	2"
DPG2650	26"	50"	2"
DPG2652	26"	52"	2"
DPG2654	26"	54"	2"
DPG2658	26"	58"	2"
DPG2660	26"	60"	2"
DPG2848	28"	48"	2"
DPG2858	28"	58"	2"
DPG3060	30"	60"	2"
DPG3260	30"	60"	2"

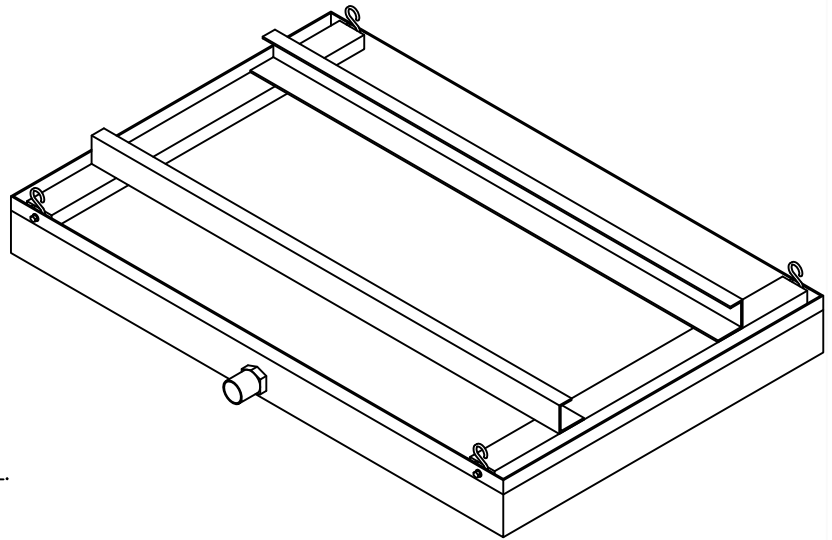

### FEATURES

GALVANIZED STEEL PROVIDES EXCELLENT CORROSION RESISTANCE AND LONGEVITY.

SEAMED CORNERS (NO WELDS) FOR A WATERTIGHT SEAL.

MAXIMUM WIDTH 36", MAXIMUM LENGTH 72".

3/4" PVC DRAIN INSTALLED.

DPG'S WITH LENGTH 60" OR GREATER INCLUDE 3 CHANNELS AND 6 HOOKS.

OPTION: CUSTOM SIZES AVAILABLE.  
EYEBOLT HANGING HARDWARE AVAILABLE  
AVAILABLE WITHOUT RAILS (DP)

JOB NAME:
LOCATION:
ARCHITECT:
ENGINEER:
CONTRACTOR:
CONTACT MIAMI TECH INC. FOR ADDITIONAL INFORMATION OR WITH SPECIAL REQUIREMENTS.
3611 NW 74TH ST MIAMI, FL 33147
PHONE: 305-693-7054 FAX: 305-693-6152
WEB: WWW.MIAMITECH.COM EMAIL: SALES@MIAMITECH.COM

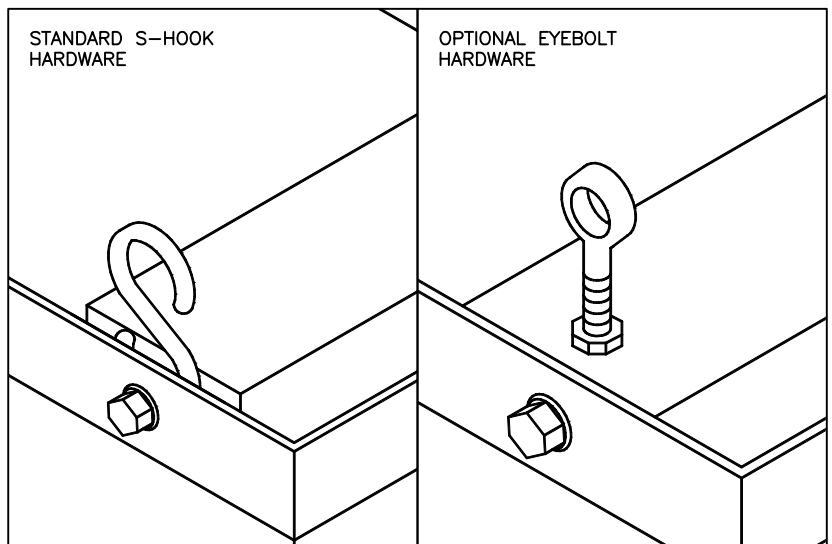

## DPG

DRAIN PAN WITH RAILS  
PRODUCT SPECIFICATIONS

NOTE: ALL DRAWINGS SUBJECT TO CHANGE WITHOUT PRIOR NOTICE.



DRAWN BY: AF	DATE: 10/17/07	SCALE: NOT TO SCALE	DRAWING NO.
CHECKED BY: IG	DATE: 4/10/12	REVISION: 2	DPG