

# Panasonic

No. : C-SBP170H16Y-01-GGS-0

## APPROVAL SHEET SPECIFICATIONS OF HERMETIC SCROLL COMPRESSOR

MODEL	C-SBP170H16Y
-------	--------------

△			
△			
△			
△			
△			
NO.	DATE	PAGE	REVISION DETAILS

REVISION RECORD

**Panasonic Appliances Compressor (Dalian) Co., Ltd.**

## Section 1. General Specifications

Content		Unit	Specification
Compressor Model (Code)		—	C-SBP170H16Y
Type		—	Hermetic Scroll Compressor
Application		—	High Back Pressure
Evap. Temp. Range		°C (°F)	-15~12 (5~54)
Compressor Cooling Type		—	Natural Cooling
Power Source	Phase	—	1
	Rated Voltage	V	208~230
	Rated Frequency	Hz	60
Voltage Range		V	187~253
Weight (Including Oil)		kg	40
Refrigerant		—	R410A
Oil Type		—	FV68S
Oil Charge		ml	1700
Displacement		cm <sup>3</sup>	55.7
Locked Rotor Ampere		A	139
Motor	Motor Type	—	1-PH Induction Motor (CSR)
	Number of Poles	—	2
	Electrical Insulation	Class	E
	Nominal Revolution	min <sup>-1</sup>	—
	Winding Resistance [at 25°C (77°F ) ]	Ω	C-S
C-R			0.365
Connection Tube	Suction Line (O.D.)	mm (in)	22.2 (0.875)
	Discharge Line (O.D.)	mm (in)	12.7 (0.500)
Compressor Surface Paint		—	Black Paint

## Notes

- 1 Voltage range is applied at standard rating conditions.
- 2 Motor specifications in the table are the average values for your reference.
- 3 ( ) : All units with parentheses are reference values.

## Expiration of Specification

Expiration of this specification shall be effected until issuing a notice with indication of the expiration date from the issued date . In case of improvement or elimination of this specification , it shall be handled by the revision record based on agreement between both sides.

**Model:** C-SBP170H16Y  
**File No:** C-SBP170H16Y-01-GGS-0

**Section 2. Performance Warranty**

**2.1 Performance**

Power Source (3PH)	Hz	60	60	Remark
	V	208	230	
Capacity	W	16,700	17,000	±5%
	(BTU/hr)	56,980	58,004	reference
Input Power	W	6,050	5,950	±5%
Current	A	30.2	16.9	±5%

**Standard Rating Conditions**

Condensing Temp.	°C (°F)	54.4(130)
Evaporating Temp.	°C (°F)	7.2( 45 )
Suction Gas Temp.	°C (°F)	18.3( 65 )
Liquid Temp.	°C (°F)	46.1(115)
Ambient Temp.	°C (°F)	35( 95 )

**2.2 Sound Level**

Power Source (3PH)	Hz	60
	V	208-230
Sound Level	dB(A)	64Max.

**Notes**

- 1 The operating conditions are the same as 2.1.
- 2 MIC location is the distance of 1m (3.28feet) from the compressor.
- 3 Sound Level is an average sound pressure level in four directions.

**2.3 Minimum Starting Voltage**

Power Source (3PH)	Hz	60
Minimum Starting Voltage	V	187

**Conditions**

Compressor Temp.	°C	10~60
Ambient Temp.	°C	10~40
High Pressure	MPa(G)	2.03
Low Pressure	MPa(G)	2.03

**2.4 Others**

Content	Unit	Specification
Design Pressure	L.P. S.	MPa(G) 2.21
	H. P. S.	MPa(G) 4.15
Insulation Resistance	MΩ	100 (without refrigerant)
Dielectric Strength (The leakage current is less than 10mA)	V	1500 (1 minute)
Residual Moisture	mg	300

**Note:**

1. The insulation resistance be measured with a DC500V megohm tester.

Model: C-SBP170H16Y

File No: C-SBP170H16Y-01-GGS-0

### Section 3. Standard Accessories

#### 3.1 Accessories List

Parts Name	Qty	Parts code	Revision No.	Note
Terminal Box Cover	1	A-0101-DSB	0	Installed on Compressor
Terminal Box Clip	1	A-0201-DSB	0	Installed on Compressor
Eyelet Rub Lead Wire	1	A-0301-DSB	0	Installed on Compressor
Mounting Grommet	4	M-0101-DSB	0	Included with Compressor
Mounting Sleeve	4	M-0201-DSB	0	Included with Compressor
Screw Special	2	B-0101-DSB	0	Installed on Compressor

#### 3.2 The Drawing for Reference

Parts Name	Parts Code	Revision No.
Compressor Outline Drawing	D-0121-DSB-0	0
Mounting Parts Listing	M-5101-DSB-0	0
Packing Dimensions	D-0202-DSB-0	0
Wiring Diagram	E-0918-DSB-0	0

#### 3.3 Internal Motor Protector (in compressor)

Parts Name	Specification	
Internal Motor Protector	Trip Temperature	160±5℃
	Reset Temperature	80±9℃
	Trip Current	Run Winding: 124A / 3~10s
		Start Winding: 48A / 3~9s

#### 3.4 Electrical Component Required but not included with compressor

Parts Name	Specification
Start Relay	P.U. 195~224V / D.O. 60~121V
Start Capacitor	100~140μF 330V (Bleed Resistor: Rf=18kΩ, 2W)
Running Capacitor	60μF 440V

Model: C-SBP170H16Y

File No: C-SBP170H16Y-01-GGS-0

### Section 4. Compressor Protection

#### 4.1 Protection Required but not Included with compressor

Protection Device	Items	Specifications
Reversal Defensible Relay	Features	To prevent the reverse rotation caused by brief power interruption
	Rated Voltage	3 minutes off / 7 minutes on
Crankcase Heater	Rated Power	35 Watts
Discharge Thermostat	Mounting Position	Located within 100mm(4 in )from the compressor shell
	Trip Temperature	130±5°C(266 ±10 °F)
	Reset Temperature	95±11°C (205 ± 20 °F)
High Pressure Switch	Setting	Cut-out seting no higher than 4.15MPa(G)
Low Pressure Switch	Setting	Cut-out seting no lower than 0.15MPa(G)

#### 4.2 Position of the Protection and Refrigerant Charging

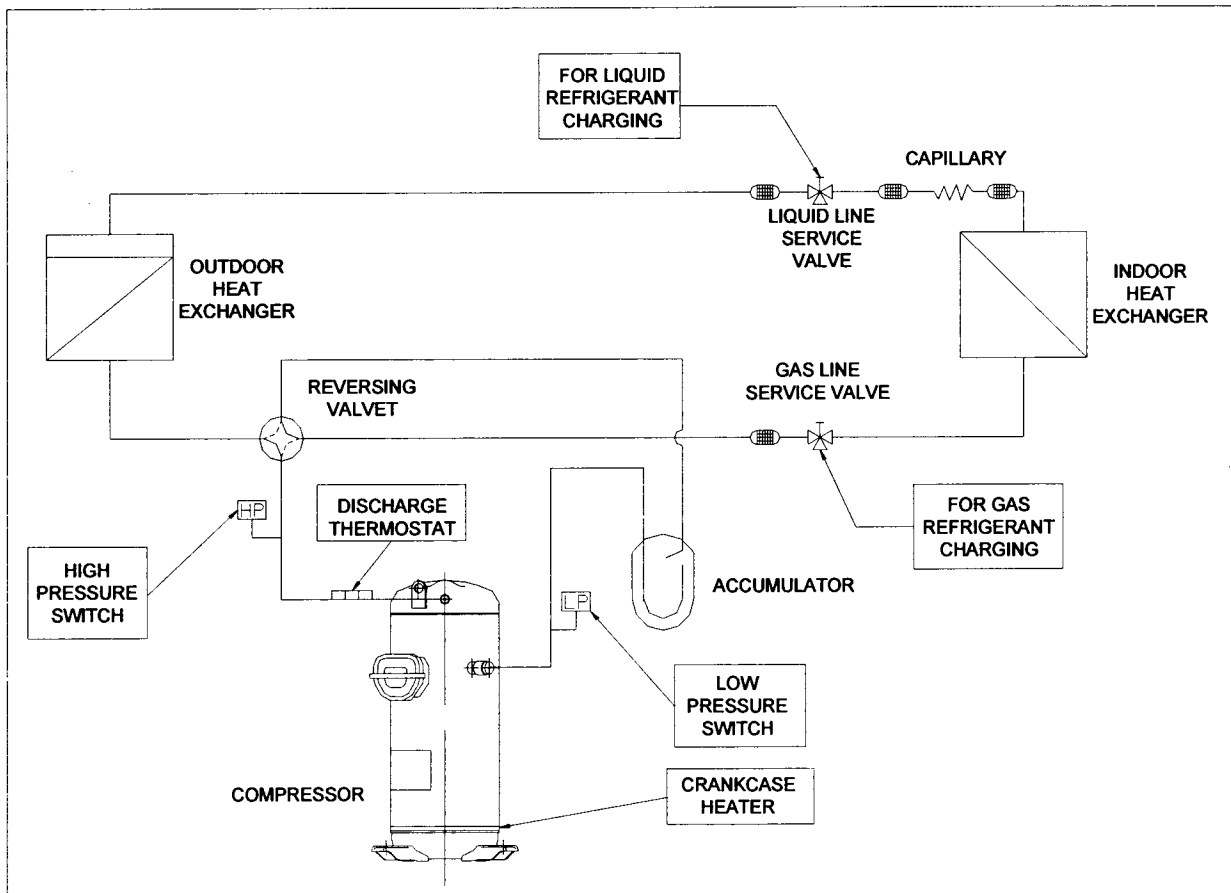

## Section 5. Operating Envelope

Suction Gas Superhea : 11.1K.  
Refrigerant : R410A.

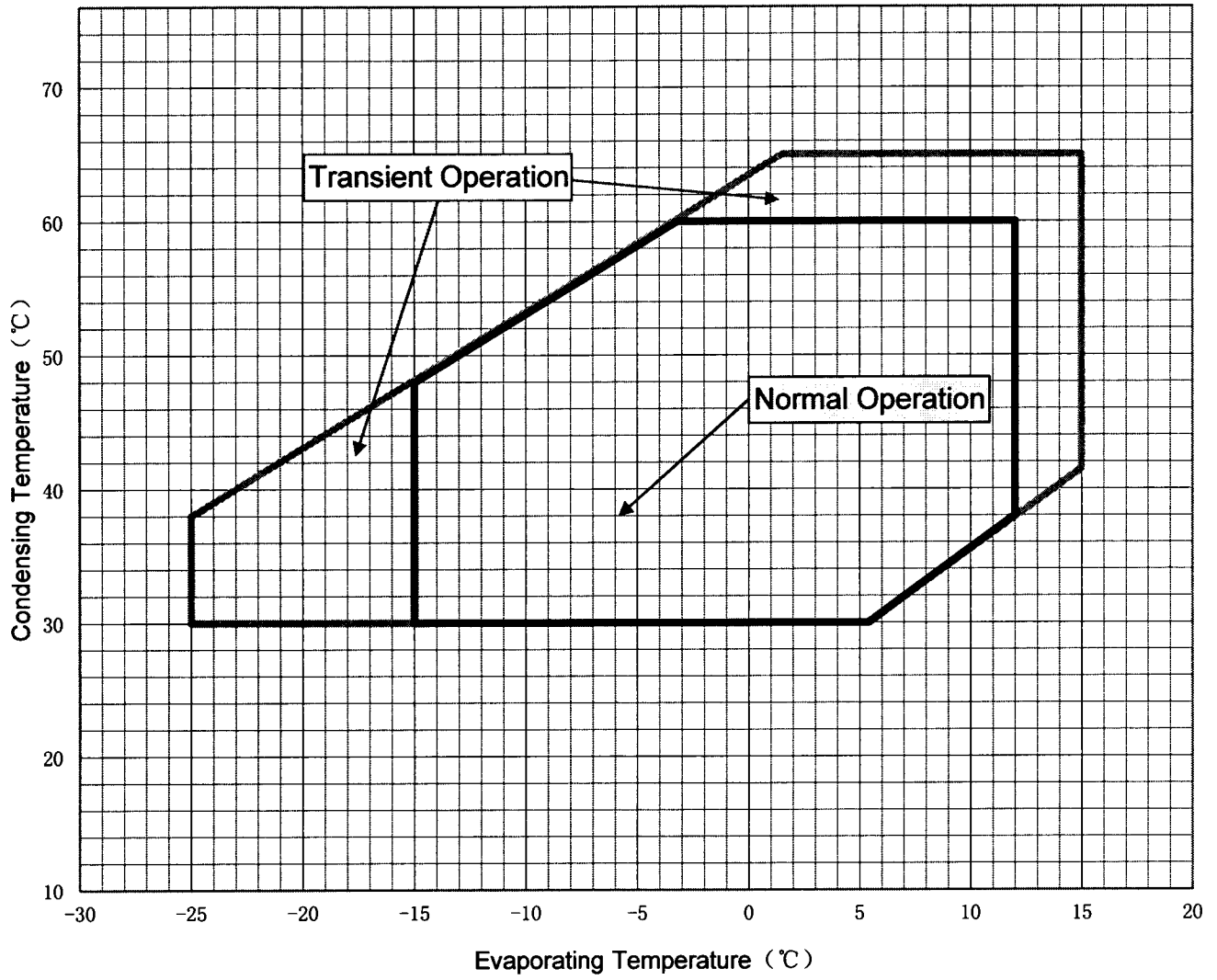

## Section 6. Application Standard & Limit

The following requirements apply to vertical type hermetic scroll compressors:

**Standard:** Applicable to ordinary conditions in Japan JIS B8616 or equivalent conditions, such as standard rating conditions, maximum operating conditions, low temperature conditions, etc.

**Limit:** Applicable to transitional brief period of time, such as start-up and beginning of defrost mode.

No.	Item	Standard	Limit	Note
1	Refrigerant	R410A		
2	Evaporating Temp.	-15~12°C(5~54 ° F) 0.38~1.05MPa(G)(55~152psig)	-25~15°C(-13~59 ° F) 0.23~1.15MPa(G)(33~167psig)	Compressor Suction Pressure
3	Condensing Temp.	30~60°C(86~140 ° F) 1.78~3.75MPa(G)(258~544psig)	65°C(149 ° F) 4.18MPa(G)(606psig)	Compressor Discharge Pressure
4	Compression Ratio	2 ~ 6	8	
5	Winding Temp.	115°C(240 °F) Max.	125°C(257 °F)	
6	Shell Bottom Temp.	Upper Limit:90°C(194 °F) Max.		When compressor is running
		Lower Limit:Evaporating Temp.+12°C(21 °F) Min.		
		Lower Limit:Ambient Temp.+11°C(20 °F) Min.		When compressor shuts off
7	Discharge Gas Temp.	115°C(240 °F) Max.	C-SB:130°C( 266°F) Max.	Temp. within 100mm(4in) of the discharge fitting.
			C-SC:135°C( 275°F) Max.	Temp. inside of the well pipe on the top of compressor
8	Suction Gas Temp.	Superheat: 5K(10 °F)Min.	No excessive noise	It should meet the requirement of item 5, 6, 7 and 14 within 30cm of the suction fitting.
9	Running Voltage	Within ±10% of the rated voltage		Voltage at compressor terminals.
10	Starting Voltage	Three Phase Models: 85% of the rated voltage min.		Dropped voltage at compressor terminals.
		Single Phase Models: 90% of the rated voltage min.		
11	On/Off Cycling	On Period: Until the oil level returns to the center of the lower bearing Off Period: Until balance of high and low pressure is obtained		For at least 7 minutes - on/3 minutes-off is recommendable. 200,000 cycle Max.
12	Refrigerant Charge	oil/refrigerant(wt.)>0.35		Specific gravity of the Oil:0.94
13	Minimum Oil Level	C-SB: Center of the lower bearing C-SB:Bottom of the lower bearing		
		C-SC:No less than 70% of the initial oil charge		
14	Abnormal Pressure Rise/Drop	Pressure Rise: 4.15MPa(G) (602psig) Max.		By high pressure switch
		Pressure Drop: 0.15MPa(G) (22psig) Min.		By low pressure switch
15	System Moisture Level	200ppm Max.		
16	System Uncondensable Gas Level	1 Vol.% Max. Residual Oxygen 0.1 Vol.% Max.		24 hrs. after vacuuming: 1.01kPa Max.
17	Tilt	5° Deg.Max.		

Operation beyond the above limits must be approved by Panasonic Appliances Compressor (Dalian) Co., Ltd.

(G): Gauge Pressure

## Notes

- 1 Installation should be completed within 15 minutes after removing the rubber plugs.
- 2 Do not use the compressor to compress air.
- 3 Do not energize the compressor under vacuumed condition.
- 4 Evacuation and Refrigerant charge : Evacuate internal section in the refrigeration system from high and low pressure sides and charge liquid refrigerant from condenser outlet side. Additional charge shall be done with gas condition from low side.
- 5 Do not tilt over the compressor while carrying it.
- 6 Do not remove the paint.
- 7 Crankcase heater is required when the oil sump temperature is too low to meet the requirement of item 6 on page 7.
- 8 Voltage fluctuation between compressor terminals, during operation, shall be within 2% of the rated voltage.
- 9 Do not operate compressor in reverse rotational direction.
- 10 Suction strainers are recommended for all applications.
- 11 Copper Piping Stress

Start/Shutdown	34.32 N/mm <sup>2</sup> Max.
Run	12.26 N/mm <sup>2</sup> Max.

## Section 7. Selection of Electrical Wire

Voltage drop may occur due to the large current draw during compressor starting.

We recommend selecting the wire size from the table below.

### 7.1 Type of Unit

#### 7.1.1 Window & Commercial Type Unit

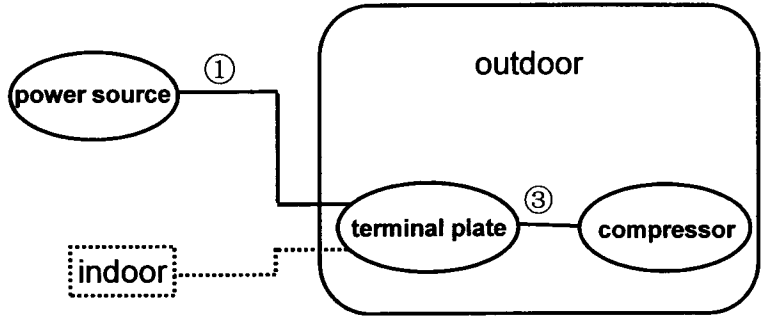

#### 7.1.2 Split Type(Separate Type)

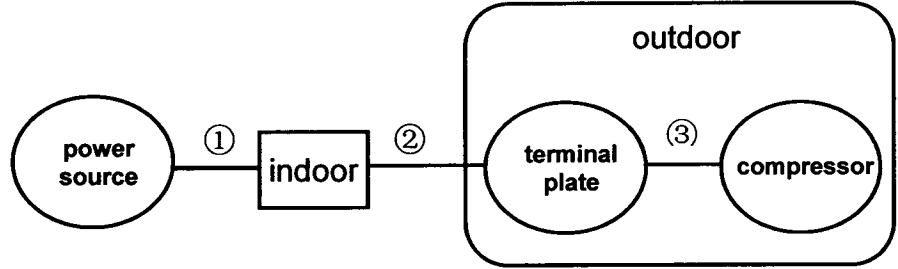

### 7.2 Size Table of Electrical Wire

Starting current (A)	Size of electrical wire (mm <sup>2</sup> )						
	Remark ① or Remark ①+② (heat-resistance Temperature: 60°C(140°F) min.)						Remark③ (heat-resistance Temperature: 120°C(248°F) min.)
	5m max.	10m max.	15m max.	20m max.	30m max.	50m max.	1m max.
20max.	2.0	2.0	2.0	3.5	5.5	8.0	2.0
30max.	↑	↑	3.5	5.5	↑	14.0	↑
40max.	↑	3.5	5.5	↑	8.0	↑	↑
50max.	↑	↑	↑	8.0	14.0	22.0	↑
60max.	↑	5.5	↑	↑	↑	↑	↑
70max.	3.5	↑	8.0	14.0	↑	↑	3.5
80max.	↑	↑	↑	↑	22.0	30.0	↑
90max.	↑	↑	14.0	↑	↑	↑	↑
100max.	↑	8.0	↑	↑	↑	38.0	↑
110max.	↑	↑	↑	↑	↑	↑	↑
120max.	5.5	↑	↑	22.0	30.0	↑	↑
140max.	↑	14.0	↑	↑	↑	50.0	5.5
160max.	↑	↑	22.0	↑	↑	↑	↑
180max.	↑	↑	↑	↑	38.0	60.0	8.0
200max.	8.0	↑	↑	30.0	↑	↑	↑
220max.	↑	↑	↑	↑	50.0	80.0	↑
240max.	↑	↑	↑	↑	↑	↑	14.0

### 7.3 Caution of Ground

The internal motor protector does not protect the compressor against all possible conditions.

Please be sure that the system utilizes the ground connection when installed in the field.

No.	Part Code	Qty	Name
1	C-SBP170H16Y	1	Compressor
2	A-0101-DSB	1	Terminal Box Cover
3	A-0201-DSB	1	Terminal Box Clip
4	A-0301-DSB	1	Insulating Grommet
5		1	Nameplate
6	B-0101-DSB	2	Screw Special

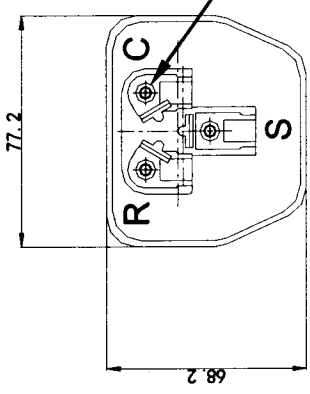
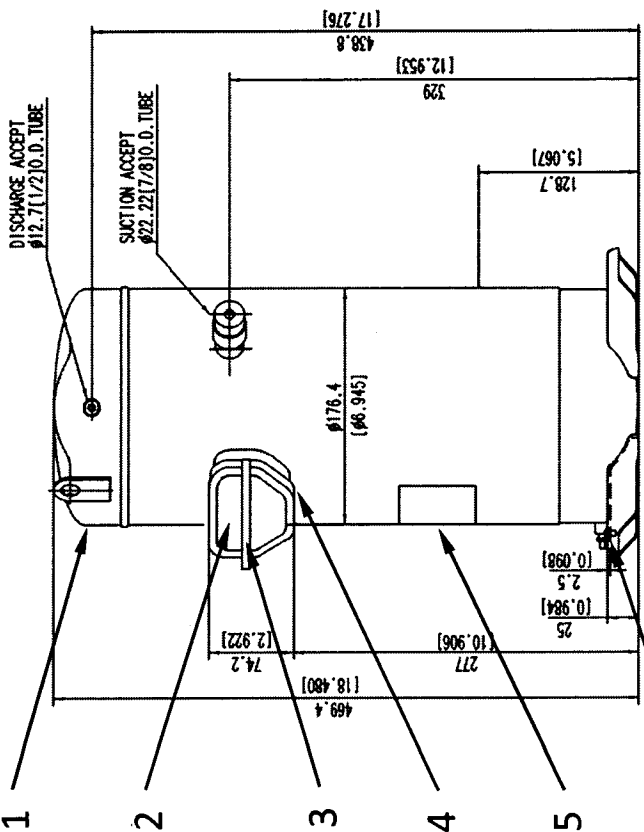

BOLT 5  
Bolt tightening torque is 2.5~3.0N·M.

TERMINAL

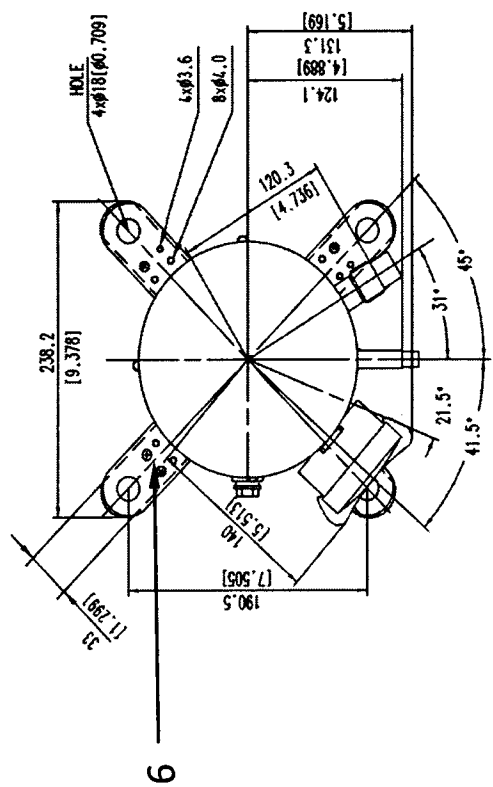

Part Code  
D-0121-DSB-0  
Name  
Compressor Outline Drawing

No.	Part	QTY	Name
1	M-0101-DSB	4	Mounting Grommet
2	M-0201-DSB	4	Mounting Sleeve
3	B-0101-DSB	1	Screw Special

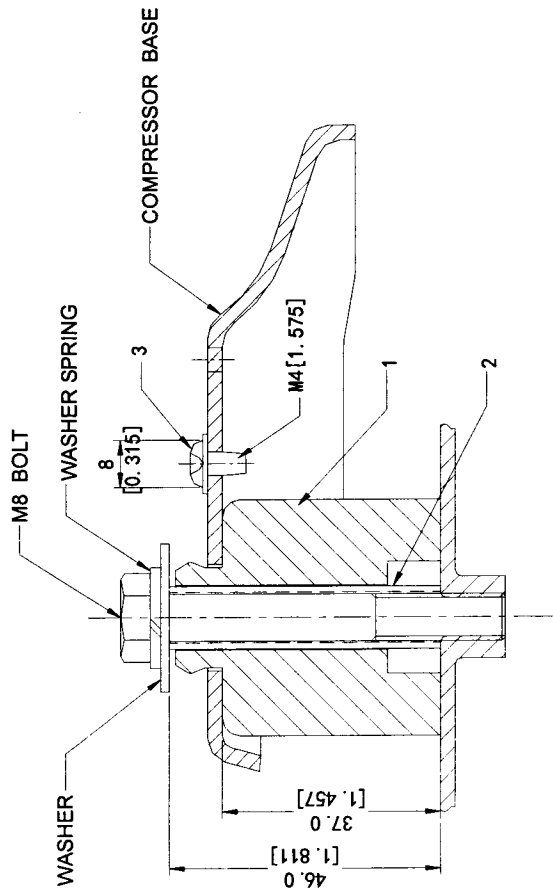
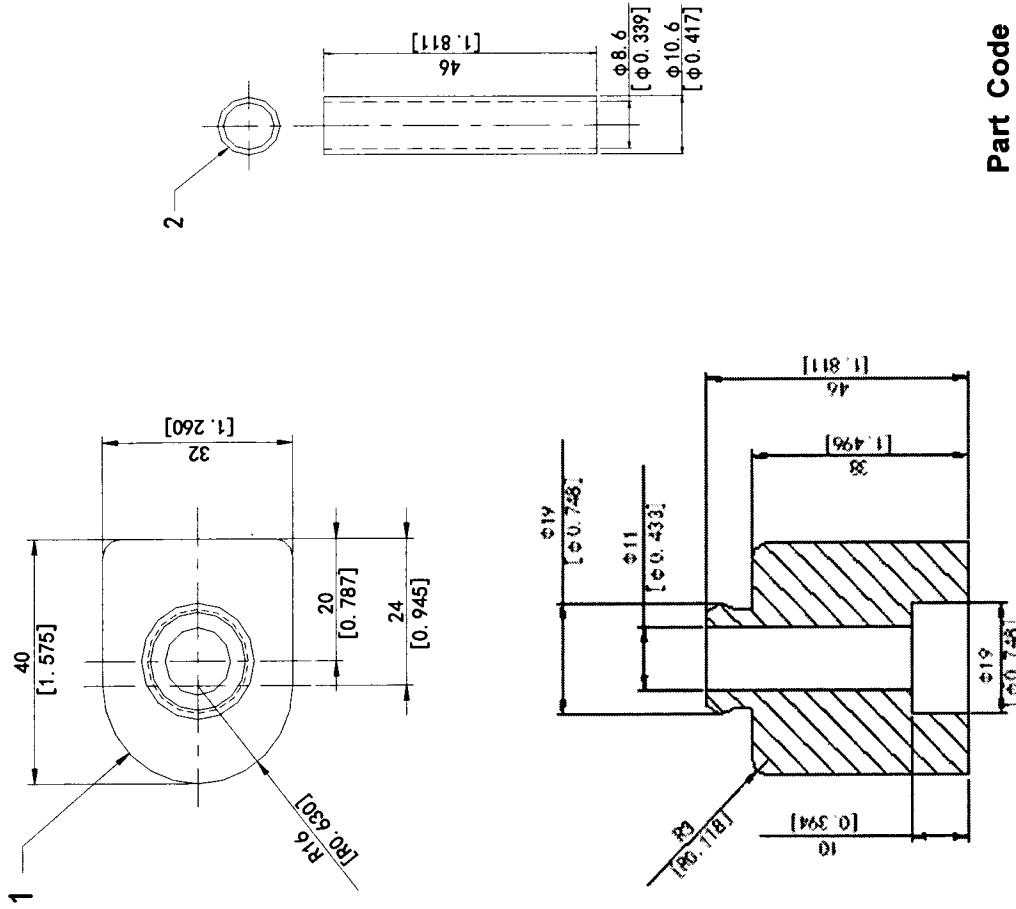

Part Code  
**M-5101-DSB-0**  
 Name  
**Mounting Parts Listing**

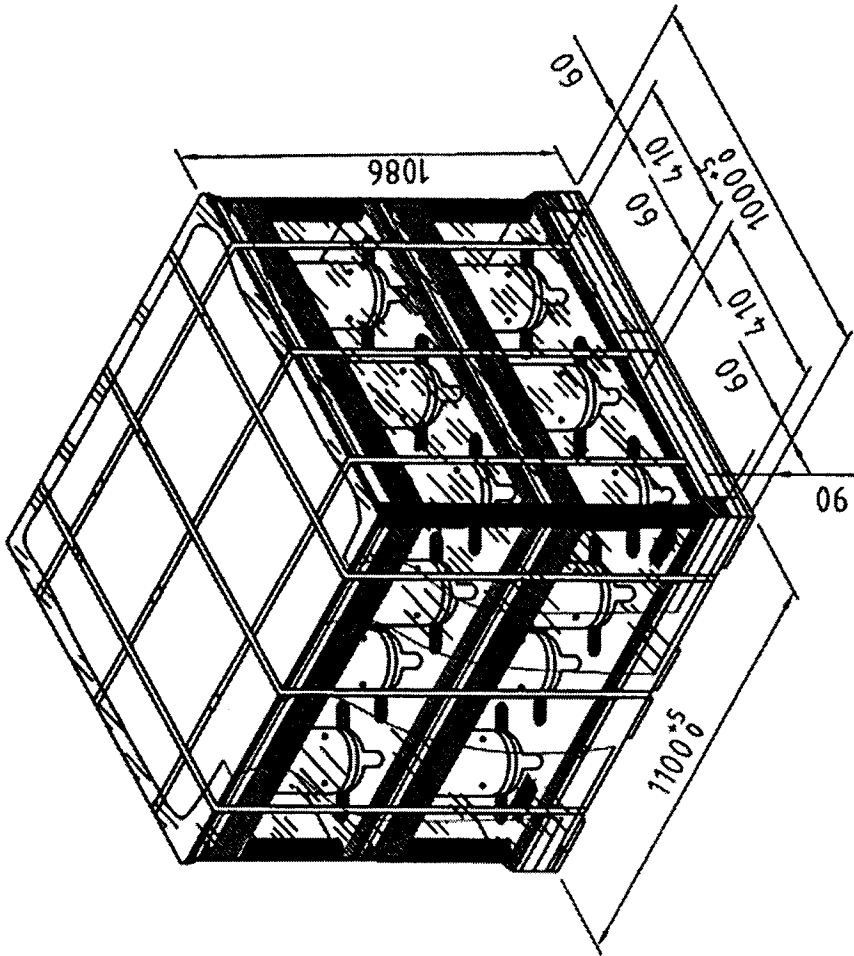

Part Code  
D-0202-DSB-0  
Name  
Packing Dimensions

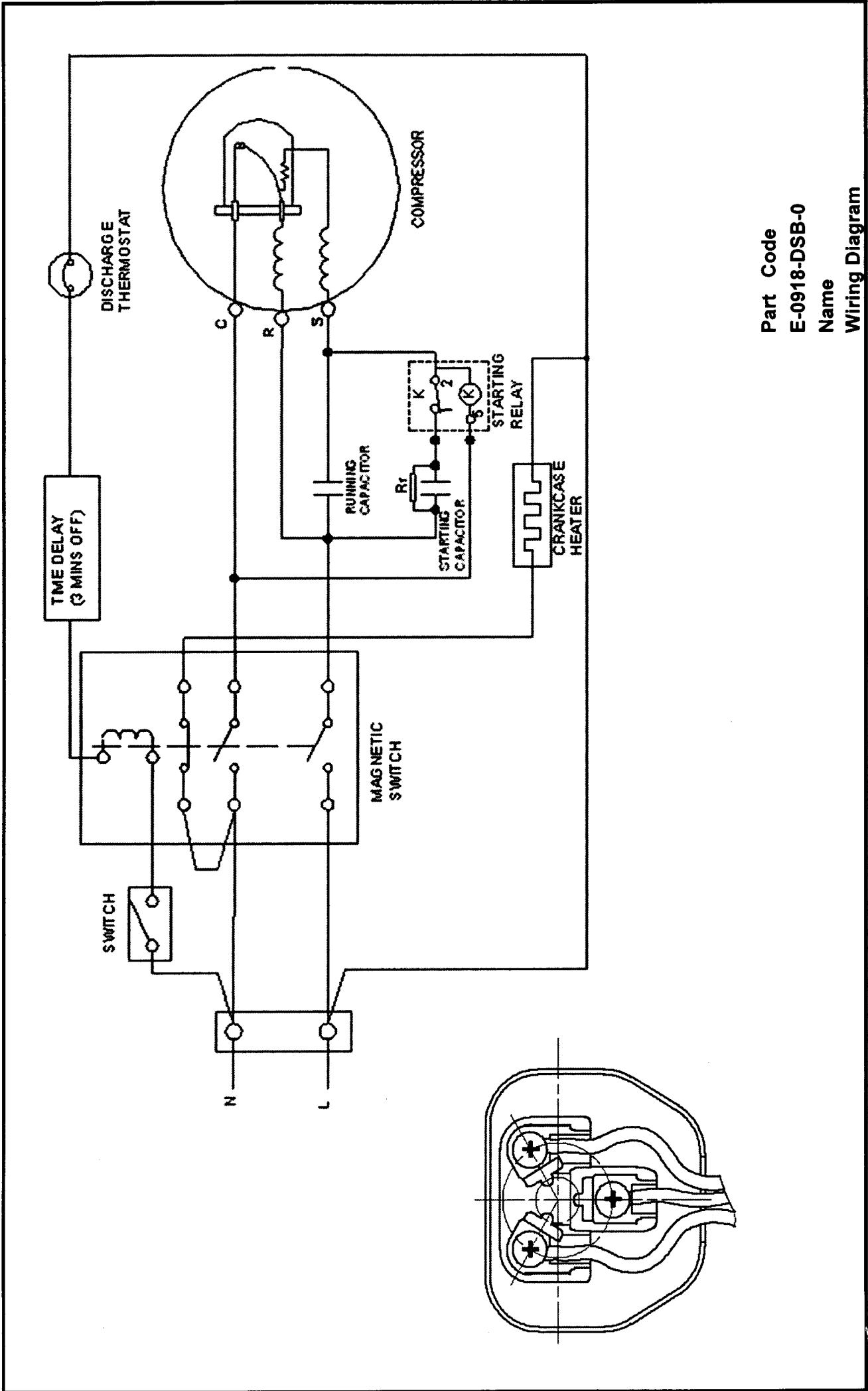

Part Code  
 E-0918-DSB-0  
 Name  
 Wiring Diagram

No.	CE - 100018E
Sheet No.	8-1

# **Compressor Specification Common Appendix**

**(for Scroll Compressor)**

**AUTHORIZED**  
2018.12.27

**Compressor Specification Common Appendix  
(for Scroll Compressor)**

No.  
Sheet-No.

CE - 100018E  
8-2

**1. Scope**

This guideline applies to Panasonic scroll compressor for air conditioning (exclude appliances in vehicle) to secure the safety ,the reliability and durability of air conditioning systems and compressor.

Since, all compressors are unique, the specifications are enacted separately.

The Contents of this general guideline may differ to the compressor specifications, so refer to the individual compressor specification instead.

**2. General Specifications of Compressors**

**2. 1. Air tight / Hydrostatic / Housing withstand pressure**

Tested in accordance to IEC GB4706.17,60335-2-34, UL984, UL60335-2-34 or JISB8620.

**2. 2. Insulation resistance**

The insulation resistance between the live and dead parts shall be 100MΩ or higher with a 500V Insulation resistance meter.

**2. 3. Insulation distance**

Compliance to JRA4050,JIS C9612 ,JIS C9335-1(IEC60335-1), UL984or UL60335-2-34.

**2. 4. Dielectric withstand voltage test**

When the rated voltage is less than 250V,

the compressor shall withstand (rated voltage 1500)

When the rated voltage is less than 600V exceed 250V,

the compressor shall withstand (rated voltage\*2+1000) AC 50Hz or 60Hz applied between the live and dead part for a continuous period of 1 minute.

If 1.2 times the said voltage is applied, the withstand period will be comparatively reduced to 1 second for mass production.

However, regulation compressors (UL, CSA, GB and so on) are specified by each compressor specification

**2. 5. Residual moisture**

Residual moisture is measured with Panasonic in-house standard, and shall follow the value mentioned in compressor specification.

**2. 7. Appearance**

The surface of the compressor must be painted black and free from cracks, dents, peeling or rust.

**2. 8. Marking**

Model name and production date should be shown on the surface of compressor.

The compressor containing refrigeration oil and dried N<sub>2</sub> gas will have a mark to indicate the pre-charge.

AUTHORIZED  
2016.12.27

**Compressor Specification Common Appendix  
(for Scroll Compressor)**

No.	CE - 100018E
Sheet-No.	8-3

**3. System Design Limitations**

**3.1. Compliance with the compressor specification**

The compressor shall operate under the condition set forth in this guideline and the compressor specification. It is prohibited to operate the compressor otherwise. The electric circuit connected to air-conditioner should equip with a fuse or circuit breaker. It will need to equip the earth leakage breaker depending on installation conditions.

**3.2. Power source voltage**

Voltage applied to the hermetic terminal shall be within the range mentioned in the compressor specification.  
In the case of inverter compressor, the compressor shall only be connected to specific inverter driver produced for this compressor. Voltage applied to the hermetic terminal shall be within the range mentioned in the compressor specification. Additionally, AC voltage( 1  $\phi$  100V, 200V, 220V, 3  $\phi$  200V.) shall never be supplied to the hermetic terminal of DC Inverter compressor as the DC brushless motor in the compressor will demagnetize.

**3.3. Suction temperature**

Higher than outlet temperature of evaporator.

**3.4. Discharge temperature**

Discharge temperature under standard condition shall not exceed 115 °C. And under overload condition, shall not exceed 130°C. Discharge temperature is measured on discharge pipe approximately 100mm away from compressor surface.

**3.5. Motor coil temperature**

The winding temperature shall not exceed 125°C under standard condition and overload condition. This measurement should be done using resistance method.

**3.6. Operating pressures and compression ratio**

Suction pressure and Discharge pressure shall be within the range mentioned in the compressor specification. During transition operation the operating pressure maybe out of the specified range mentioned in the specification, they may be approved by checking operating data.

**3.7. Starting and maximum current of compressor**

Starting current and maximum current shall be within the range mentioned in the compressor specification. In the case of inverter compressor, if the current is over the limitation, DC brushless motor will demagnetized and compressor will not be operate.

**3.8. Liquid refrigerant back**

Liquid refrigerant flood back can be root of liquid compression that will cause knocking noise, current surge and undesirable vibration.  
<Liquid compression can trigger serious damage for mechanical-parts.>  
To resolve this, the following could be implemented to prevent liquid refrigerant flood back.

- 1) Add another accumulator or increase internal capacity of accumulator
- 2) Decrease refrigerant charge amount
- 3) Change operation mode

<b>AUTHORIZED</b>
2015.12.27

**Compressor Specification Common Appendix  
(for Scroll Compressor)**

No.  
Sheet-No.

CE - 100018E  
8-4

**3. 9. Oil level of compressor**

The minimum oil level in compressor shall follow the contents mentioned in the compressor specification to maintain reliability.

In the case of foaming, the height of this foam does not mean the height of the oil level.

The lack of oil level can seriously affect to compressor reliability.

(Please check the oil level by a compressor with sight glass supplied by us and submit the result to us.)

**<<Example showed the oil level to keep>>**

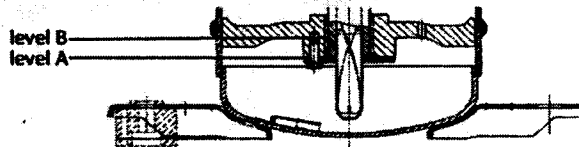

- level A : the lowest oil level during transition operation
- level B : the lowest oil level during stable operation

**3.10. Pipe surface stress**

The stress of pipes connecting the compressor and other parts of the refrigeration systems, shall not be more than 12.26MPa when the compressor is operating, and shall not be more than 34.32MPa during 'start - stop'.

**3.11. Allowable Incline**

The allowable incline shall not be more than 5° during operation.

**3.12. Rate of revolution speed change**

The rate of revolution speed change shall not be more than  $60\text{min}^{-1}/\text{s}$ . This is to prevent the damage of sliding portion of bearing parts by rapid change of rotation.

**3.13. Starting of compressor**

Inverter compressors shall keep it for one minute after the rotation speed attained at  $1800\text{min}^{-1}$ .

Because it is to prevent the oil lack to sliding portion by oil level down at compressor-start. To check oil return, perform a test using a sight glass compressor supplied by us. Similar actions also applies to restart operations after defrost cycle.

**3.14. Defrost operation**

Inverter compressors shall operate at low speed right before the start of defrost cycle and right before the end of defrost cycle. This will enable the oil to be retained in the compressor. To check oil return, perform a test using a sight glass compressor supplied by us.

**3.15. Cautions of transition phase to lower speed operation**

When the inverter scroll compressor transit to low speed operation of below  $1500\text{min}^{-1}$ , be careful the the rapid differential pressure decrease and liquid refrigerant flood back.

This phenomenon causes the separation of orbiting scroll and fixed scroll and the rapid capacity decreases as a result.

AUTHORIZED  
2016.12.27

**Compressor Specification Common Appendix  
(for Scroll Compressor)**

No.	CE - 100018E
Sheet-No.	8-5

**3.16. Caution for continuous low speed operations**

When the inverter scroll compressor be operated more than 30minutes at rotation speeds lower than  $1500\text{min}^{-1}$  , it needs to operate for more than 5sec at the rotational speed more than  $1500\text{min}^{-1}$ .  
Because it gets appropriate lubrication.

**3.17. On/off cycle**

The on/off cycle of compressor shall not be more than 6 cycles per hour.  
The compressor should be operated continuously at least for 5 minutes after being turned on. Allow a minimum of 3 minutes shut-off time before restarting.  
Or restart the compressor after the pressure difference between high side and low side balances.

**3.18. Rotation direction of compressor**

Wiring shall be connected in accordance with the wiring diagram mentioned in the compressor specification. Otherwise the compressor will run into reverse operation and breakdown. Never do this.

**3.19. Protection against dust at hermetic terminal**

Hermetic terminal(s) shall be covered with the terminal cover using the designated method to prevent / reduce dust impregnation.

**3.20. Strainer**

To prevent foreign particles coming in the compressor inside, it shall install the strainer with screen on the way to suction line piping.  
The strainer shall be more than 30mm in diameter and a screen mesh size of 100.  
In case that the suction line have an accumulator with screen, the strainer will not be required.

**3.21. Dryer**

When residual moisture in the refrigerating system for R410A is over 100ppm, the refrigerant cycle shall equip with a dryer.

**4. Process Limitations**

**4. 1. System and heat exchanger contamination**

The weight of foreign particles in the refrigerating system (in the copper tube of heat exchanger or in the copper piping) shall not be more than 75 mg.

**4. 2. Refrigerant gas charging**

Refrigerant shall charge from the condenser outlet of the refrigeration system.  
Never charge directly refrigerant to the compressor.

**4. 3. Caution on charging refrigerant**

The compressor should be operated for more than 20sec within 15min intervals after the refrigerant is charged.  
Because it gets proper lubrication to sliding portion.

**4. 4. Air conditioner inspection**

Even during the inspection process of air-conditioner, a compressor shall operate within compressor specification.

AUTHORIZED  
2016.12.27

**Compressor Specification Common Appendix  
(for Scroll Compressor)**

No.

CE - 100018E

Sheet-No.

8-6

**4. 5. Air conditioner inspection (Inverter compressor)**

If the inverter compressor operates at higher speed during inspection process, it shall then operate at low speed to return the oil to shell, and subsequently stop.

**5. Miscellaneous (DO & DON'T)**

**5. 1. Air running**

It shall not allow to operate the compressor without refrigerant.  
It shall not allow to disconnect the connection pipe during pump-down operation.  
If the connection pipe is disconnected when the stop valve is open during pump-down operation, air will be sucked and the refrigerant cycles becomes a state of extreme high pressure. It may cause the compressor explosion.

**5. 2. Vacuum operation**

It shall not allow to operate the compressor under vacuum.  
Internal arcing will occur and it is very dangerous.  
In case of operating compressor under vacuum to expedite evacuating in refrigerant cycles, internal arcing will occur and motor insulation will be damaged.

**5. 3. Electric pulse**

Do not supply electric pulse to the hermetic terminals when the compressor is being vacuumed.

**5. 4. Caution on pump down operation**

At the pump-down operation, a compressor rotation speed shall be lower than  $3600\text{min}^{-1}$ .  
The operation time shall not exceed a limit of 10 minutes.

**5. 5. Compressor shaking**

Do not shake the compressor during operation.  
(Do not use it for transportation application.)

**5. 6. Low limit of system temperature**

In order to prevent oil quality deterioration, the temperatures in HBP systems shall not be less than  $-35^{\circ}\text{C}$ , the temperatures in LBP systems shall not be less than  $-50^{\circ}\text{C}$ .

**5. 7. Operating at low ambient temperature**

A crankcase heater should be used for the system with high refrigerant charge volume, for example, the split type floor standing system. The crankcase heater of suitable power should remain the temperature of compressor bottom shell  $11\text{K}$  higher than ambient temperature or reduce the oil level to specified level after 5 hours energizing.  
The crankcase heater must be energized for a minimum of 5 hours prior to starting compressor.

**5. 8. Operation at corrosive atmosphere.**

The compressor should not be used in a corrosive atmosphere, such as chemicals storage area.

**5. 9. Safety issues relating to gas leakage**

To prevent the accidents caused by refrigerant leakage, a thermister should be facilitated at the discharge tube of the compressor. If the temperature reaches abnormally high, the thermister will stop the compressor.

AUTHORIZED  
2016.12.27

**Compressor Specification Common Appendix  
(for Scroll Compressor)**

No.	CE - 100018E
Sheet-No.	8-7

**5.10. Mixing refrigerant oils**

Mixture of refrigerant oil shall never be done.  
Oil amount in compressor shall be in line with compressor specification.  
(Too little will decrease the reliability , too much will decrease the performance)  
Refrigerant and oil other than specified shall not be used. Refrigerant purity shall be controlled.  
The above shall also be observed in the market. Refrigerant purity shall refer to Attachment 1.

**5.11. Electrical safety - Connecting lead wire(s) to the compressor**

The lead wires should be connected to the hermetic terminals without touching the surface of compressor.

**5.12. Electrical safety - Water splashing**

The unit design must be made to pass the tests (water spray test and etc.), with consideration on the environment in which the product is to be installed.  
The structure must be designed to avoid continuous contact of compressor surface and water from the sound proof material absorption, suction pipe condensation and others.

**5.13. Compressor storage**

The compressor should be stored in a clean place with low moisture.  
Do not store compressors outside (outdoor).  
A storage under high temperature ambience may cause the blowing of rubber seal cap.  
And also, storage under high temperature and humidity ambience may cause strength decrease of packing case and collapse

**5.14. Compressor status at process line.**

The compressor discharge and suction tubes shall not be left open to the atmosphere for more than 15 minutes.

**5.15. Compressor handling**

Handle the compressor not so as to bent the pins of the hermetic terminal.

**5.16. Compressor handling**

The compressor(s) dropped intentionally or accidentally, should not be used.

**5.17. Accessory**

Panaasonic's original standard parts or approved ones shall be used.  
Regarding start and run capacitors, please use the protection level P2 or S2 capacitors of IEC60252-1. It is also to pay attention to the installation location (cooling, water proof and dust-free), environment and surface temperature of it .  
It also can cause the ignition by aged deterioration. To prevent the spread of fire, the surrounding of capacitor shall be enclosed with metal or plastic rated UL 94V-0 or higher.

**5.18. Spacing between grommet and fastening nut.**

Spacing between grommet and fastening shall secure the space of 0.5 to 2 mm.

**5.19. Lead wire insulation**

The lead wire connected to the hermetic terminal shall not contain any substance that will emit corrosive gas (ex. Chlorine gas ).

**5.20. Inquiry**

If you have any questions for compressor using, please contact us.



**5.21. Application obligation**

Panasonic Corporation has no obligation to any problem occurring if the usage of compressor is not complied appropriately with compressor specification.

# Attachment 1. Refrigerant Purity

No.	CE - 100018E
Sheet-No.	8-8

## HCFC-22

Purity	99.5 wt% min
Vapor Content	100 wt ppm max
Acid Content (HCl Conversion)	1 wt ppm max
Moisture Content	10 wt ppm max
Non-Condensable Gas	1.5 vol% max

## HFC-134a

Purity	99.5 wt% min
Vapor Content	100 wt ppm max
Acid Content (HCl Conversion)	1 wt ppm max
Moisture Content	10 wt ppm max
Non-Condensable Gas	1.5 vol% max

## HFC-407C

Structure : Composition (wt%)	HFC32 : 23 ± 2.0 wt% HFC125 : 25 ± 2.0 wt% HFC134a : 52 ± 2.0 wt%
Purity	Each composition at 99.5 wt% min
Vapor Content	100 wt ppm max
Acid Content (HCl Conversion)	1 wt ppm max
Moisture Content	10 wt ppm max
Non-Condensable Gas	1.5 vol% max

## HFC-410A

Structure : Composition (wt%)	HFC32 : 50 ± 1.5 wt% HFC125 : 50 ± 1.5 wt%
Purity	Each composition at 99.5 wt% min
Vapor Content	100 wt ppm max
Acid Content (HCl Conversion)	1 wt ppm max
Moisture Content	10 wt ppm max
Non-Condensable Gas	1.5 vol% max

## HFC-32

Purity	99.5 wt% min
Vapor Content	100 wt ppm max
Acid Content (HCl Conversion)	1 wt ppm max
Moisture Content	10 wt ppm max
Non-Condensable Gas	1.5 vol% max

## HFC-404A

Structure : Composition (wt%)	HFC125 : 44 ± 2.0 wt% HFC143a : 52 ± 2.0 wt% HFC134a : 4 ± 2.0 wt%
Purity	Each composition at 99.5 wt% min
Vapor Content	100 wt ppm max
Acid Content (HCl Conversion)	1 wt ppm max
Moisture Content	10 wt ppm max
Non-Condensable Gas	1.5 vol% max

## R744 (CO2)

Purity	99.9 vol% min
Water Content	10 wt ppm max
Gas Impurities (H2, N2, O2, Ar)	1.5 vol% max

AUTHORIZED  
 2016.12.27

# Safety Request on the Use of Compressor

## <Contents>

	Page
<b>1. Application</b>	... (11-2)
<b>2. Objective</b>	... (11-2)
<b>3. Definition of terminology</b>	... (11-2)
<b>4. Basic safety design of compressor</b>	... (11-2)
<b>5. Anticipated problems on safety(productliability)</b>	... (11-3)
<b>6. Safety request items at the unit design</b>	... (11-4)
<b>7. Safety request items at the unit production</b>	... (11-6)
<b>8. Safety request items at installation, inspection and repair</b>	... (11-7)
<b>9. Safety request items at storage and transport</b>	... (11-8)
<b>10. For usage other than air-conditioner and freezer and water heater application</b>	... (11-9)
<b>11. Appeal for attention to end users and service personnel</b>	... (11-9)
<b>Attachment 1. Safety indication (warning label) of the compressor</b>	... (11-10)
<b>Attachment 2. Refrigerant Purity</b>	... (11-11)

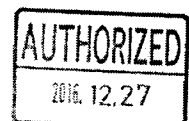

No	CE-100017E
Sheet.No	11-2

## 1. Application

This safety instruction applies to the following hermetic compressor (here after will be known as "compressor" ; exclude automobile use) , produced and sold by "Refrigeration and Air-Conditioning Devices Business Division, Panasonic Corporation" and "Panasonic Appliances Compressor (Dalian) Co., Ltd." (here after will be known as "our company")

Scroll type compressor  
Rotary type compressor

## 2. Objective

The aim of this information is to ensure the safety of an Air-Conditioning and related parts (here after will be known as product 'unit') from the compressor safety's view point. Our company will not be liable if the following safety instructions are not observed.

## 3. Definition of terminology

The terminology that is not mentioned in the text shall be referred to or in accordance to JIS Standard for Room Air-Conditioning (JIS C 9612-2005).

## 4. Basic safety design of compressor

- (1) Compressor has a compression mechanism and motor in its hermetic pressure vessel.
- (2) The hermetic pressure vessel is designed to be in compliance with the following safety regulations
  - UL984,UL60335-2-34
  - IEC60335-2-34
  - JISB 8620
  - JRA 4050
  - GB 4706.17
  - High Pressure Gas Safety Act
- (3) The electric components (e.g overload protector) is designed to be in compliance with the following safety regulations.
  - UL984,UL60335-2-34
  - IEC60335-1,IEC60335-2-34
  - JIS C9612
  - PSE (The Electrical Appliance and Material Safety Law"Denanhou")
  - JRA 4050
- (4) The plastic resin of the compressor terminal cover contains self extinguishing and flame resistant materials, and that is designed to be in compliance with UL984 and UL60335-2-34.

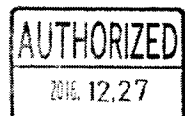

No	CE-100017E
Sheet.No	11-3

## 5. Anticipated problem on safety (product liability)

### (1) Electric shock

#### Contact with live parts (hermetic terminal)

If the terminal cover is properly installed, the live parts will not be directly exposed. However, an individual might be subjected to electric shock if came into contact with the hermetic terminal while electricity is supplied, and also when the terminal cover is removed while performing an inspection or repair.

#### Electrical leakage due to motor burn

Motor burn might occur due to the following causes. The compressor itself will never ignite by itself, however in the case of being short circuited to non-live parts, electric shock may occur due to an electrical leakage.

#### <Common example of motor burn>

- Wrong power supply ... when the compressor is supplied with power rating other than that mentioned in the compressor specification.
- Wrong wiring ... when wiring other than that mentioned in the circuit diagram of the compressor specification is made.
- Non-original parts employment ... when a parts other than specified in the compressor specifications is employed.
- Gas leak operation ... when the operation of the compressor is performed with inadequate amount of refrigerant.
- In vacuum operation ... when the compressor is operated while evacuating so as to make evacuating quicker in the refrigerant cycle.
- Air operation ... when the compressor is operated while the refrigerant cycle is exposed to air.
- Parts abnormality ... abnormality or defective OLP, capacitor, and etc.
- Others ... lightning strike , instantaneous blackout, quality defect and etc.

### (2) Explosion , fire

The hermetic pressure vessel will never leak or destruct as long as it has been operated below the permissible limit (pressure, current, temperature, ambient condition and so on) mentioned in the compressor specification. However, for the following exceptional cases, the refrigerant gas and refrigerant oil may leak (spout) out of the compressor.

#### •Explosion due to airbreathing operation (Diesel explosion)

In the case that the compressor is operated with condition mixing air into the refrigerant cycle under the following abnormal work, the refrigerant oil enclosed in compressor become mist state and can trigger the explosion by self-ignition under high-temperature and high-pressure condition.

(The cases that the diesel explosion occur)

- The case that a compressor is operated under the service-valve open state without connecting the refrigerant pipe
  - The case that operates a compressor without refrigerant.
  - The case that a connection pipe is removed during compressor operation.
- (The air-breathing operation occurs at above three modes)
- The case that the refrigerant other than specified one is charged..

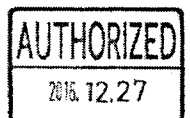

No	CE-100017E
Sheet.No	11-4

**Leak due to the hermetic terminal insulation glass melting (terminal blowout)**

In the following situation, when a large current flows through the hermetic terminal instantaneously, the insulation glass melts and crack-open.

The refrigerant gas and refrigerant oil might leak (spout) out of the compressor.

<Example of situation where large current flows through the hermetic terminal.>

- Short-circuit by the adhesion of foreign object (sand, dust, water content, etc.) to the insulation glass part.
- Internal electricity discharges due to operation in vacuum. (Compressor operation during evacuation)
- Burning and damage of motor.

**Usage of refrigerant gas or refrigeration oil other than specified**

In the event whereby different refrigerant or refrigeration oil other than specified is charged into the refrigeration and air-conditioning system, it might cause mechanical defect, faulty operation or breakdown. Hence, it is feared that it might implicate significant defect to the safety assurance.

**Leakage due to corrosion of hermetic pressure vessel**

When the compressor is used for a long time under a severe corrosion-causing environment, the internal refrigerant gas and refrigeration oil might leak (spout) due to the corrosion of hermetic pressure vessel.

When a leakage occurs, the internal refrigerant gas and refrigeration oil will spout out momentarily in the form of a white spray or foam, but this is not an explosion or smoke due to combustion.

If the connecting pipe to the compressor discharge pipe is removed for inspection or repair, by using a brazing torch while the refrigerant gas (pressured) remains still in the compressor, the internal high pressure refrigerant gas and refrigeration oil might suddenly spout out and this situation is very dangerous for person.

Further, if the flame of the brazing torch comes into contact with the refrigerant gas or refrigeration oil, a toxic gas may be generated or may cause a fire.

Do not mix air or etc., others than the designated refrigerant into the refrigeration cycle.

Mixing with air or etc. might cause an abnormally high pressure in the refrigerant cycle and this situation triggers rupture and injury.

**(3) Skin burn**

The compressor surface, during operation or immediately after ceasing operation, will still be "HOT".

This will cause burns to the skin, if an individual comes in contact with the HOT surface.

(The compressor surface temperature may be reached up to 150°C.)

**6. Safety request items during the unit design**

- (1) The unit must be designed in such that the compressor is operated in the specified range of refrigerant, rated power supply, temperature, pressure and etc. as mentioned in the specifications. Further, Panasonic's original standard parts or approved parts, such as OLP, terminal cover, gasket, retainer, spring and etc., must be employed.



No	CE-100017E
Sheet.No	11-5

- (2) Provide a ground to the unit and be sure to ground at installation. Further, for safety reasons, provide fuse(s), abnormal current protection circuit(s) or etc. to the product, depending on the necessity.
- (3) The hermetic terminal portion must be designed in a way which is not easily exposed to electrically conductive object e.g. water, foreign object, metal powder, sand, insect or etc. If there is any potential exposure of the conductive object, apply the gasket sheet for terminal cover and fill up the mouth of the terminal cover with sealing material.
- (4) In the case of usage in a severe environment or condition is anticipated (seaside, volcanic hot spring, chemical erosion gas area, dusty area and etc.), take precautions by having an anti-corrosion structure or sealing of hermetic terminal surrounding etc.
- (5) A wrongly connected 3-phase power supply wiring could become the cause of compressor burn due to reverse rotation of the compressor. Install a phase detector in the electric circuit to prevent current flows to compressor in the case of miss-connection.
- (6) In the event of an instantaneous power dip (cut), the reverse rotation of the compressor may occur and result in compressor burn. Therefore, the design must consider the prevention of reverse rotation by making the motor to stop in the event of an instantaneous power dip (cut).
- (7) Regarding start and run capacitors, please use the protection level P2 or S2 capacitors of IEC60252-1. It is also to pay attention to the installation location (cooling, water proof and dust-free), environment and surface temperature of it. It also can cause the ignition by aged deterioration. To prevent the spread of fire, the surrounding of capacitor shall be enclosed with metal or plastic rated UL 94V-0 or higher.
- (8) The specifications (size, heat resistance of insulation cover material and etc.) of the lead wires and terminals to be connected to the compressor must be made from the ones that are able to withstand the respective maximum current and properly comply with the standard of the unit.
- (9) In the case of portable or mobile dehumidifier and air-conditioner, consideration must be given to ground the product. This can be easily done by the employing a plug with ground etc.
- (10) In the case that units having built-in water taken such as dehumidifier, movable air-conditioner or etc., is suspected that it can easily fall or topple down, design protection way of electrical shock and electrical leakage due to water leakage at falling.
- (11) The low-pressure pipe must not be located above the hermetic terminal of compressor because its surface will form dew condensation and water droplets will accumulated on the compressor surface.
- (12) The unit design must be made to pass the tests (water spray test and etc.), with consideration on the environment in which the product is to be installed. The structure must be designed to avoid continuous contact of compressor surface and water from the sound proof material absorption, suction pipe condensation and others.



No	CE-100017E
Sheet.No	11-6

- (13) If a protection cap is to be placed at the wire-connection portion, it should be made of a heat-resistance material. The usage of vinyl chloride shall not allow..  
(Vinyl chloride generates chlorine gas at high temperature and rusts the neighboring metal).
- (14) If the insulation glass of the hermetic terminal melts and opens, the lead pin (metal) may be spout out. Though it will never fly out breaking the terminal cover, however, from the safety point of view, the outside case covering above area of the terminal cover need to have a strong structure.
- (15) Compressor surface may heat-up to as high as 150°C. Parts/materials that may come in to contact with the compressor surface should be designed with adequate heat-resistance.
- (16) In the case that the up and down cycle of pressure in compressor housing is expected to be more than 1.0MPa in a short period due to bypass operation or temporary stopping of fan and it occurs periodically during the normal operation of compressor, a reliability of compressor in long life using can be detracted . In the case that above mentioned operation can be expected, conducts the durability test to secure the compressor reliability.

## 7. Safety request item during the unit production

- (1) Do not operate the compressor in airbreathing or vacuum state.  
During operation, the refrigerant tubes must be connected securely not to breathe a air.  
For Pump-down operation, please stop the compressor before removing refrigerant tubes.  
If refrigerant tubes are removed without stopping compressor, air will be sucked-in, an abnormally high pressure will build-up in the refrigerant cycle. It might explode the compressor housing and cause injuries. Please state this item clearly in the unit's operation/installation maunal to ensure proper operaton/installation.
- (2) Do not allow water or foreign objects to remain in the terminal cover and keep the hermetic terminal clean.
- (3) Please handle the hermetic terminal with extra care and do not apply excessive force or shock(such as knocking).  
Please protect the flame of torch not to make the temperature of the terminal portion raise at brazing work of dischage tube.(Protection of brazing torch flame)  
The above mentioned works may cause the terminal to chip or crack and subsequently refrigerant leakage or short-circuit of power supply.
- (4) The terminal cover must be fixed properly and ensure that there is no pinching of lead wire by terminal cover edge.
- (5) Pay attention not to block the piping internal with brazing residue during brazing.
- (6) In case that air-blow is used to get rid of condensing water which occurred at unit running test or inspection test, make sure that there is no moisture remaining around the power supply parts. And if a unit is packed with plastic bag after air-blow process, dew-drops may accumulate around the power supply parts.  
Take consideration to insert a desiccant in it to prevent this phenomenon.
- (7) Do not use refrigerant or refrigerant oil other than designated/specified.  
Control the refrigerant purity. The purity is referred to Attachment 2.

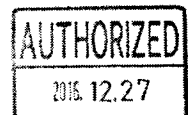

No	CE-100017E
Sheet.No	11-7

## 8. Safety considerations during installation, inspection and repair (including during development experiment)

- (1) Be sure to ground the unit.  
When performing an inspection or a repair work, make sure the unit is grounded.
- (2) Before starting any work on the unit, disconnect power supply.
- (3) Properly fix the terminal cover before supplying electricity.  
Be sure not to run compressor without terminal cover.
- (4) Wear safety goggles when performing an inspection or repair on the compressor.
- (5) When a brazing torch is used to remove the piping of the compressor from the unit, perform it after completely evacuating the refrigerant gas.  
If the connecting pipes are removed by using brazing torch under existing pressurized refrigerant in cycles at inspection or repair work, the internal high pressure refrigerant gas and refrigeration oil might suddenly spout out and is very dangerous.  
Further if the flame or the brazing torch comes into contact with the refrigerant gas or refrigeration oil, a toxic gas may be generated and even cause fire.
- (6) Please do not operate the compressor in airbrathing and vacuum state.

During installation, please ensure all the refrigerant tubes are completely connected before operating the compressor.

If the refrigerant tubes are not connected and the compressor is operated when the service valve is open, air will be sucked-in and an abnormally high pressure will build-up in the refrigerant cycle. The compressor may explode and cause injuries.

For pump-down operation, please ensure the compressor is stopped before removing refrigerant tubes. If the refrigerant tubes are removed when the compressor is still in operation, air will be sucked-in and an abnormally high pressure will build-up in the refrigerant cycle. The compressor may explode and cause injuries

In the case of transferring the A/C, other then specified refrigerant (eg. R410A), please do not mix any other gas such as air into the refrigerant cycle. By doing so, an abnormally high pressure will build-up in the refrigerant cycle. The compressor may explode and cause injuries. Please state this item clearly in the unit's operation/installation maunal to ensure proper operation/installation.

Please limit the work only to a qualified person because it is a special work.

- (7) Do not use refrigerant or refrigeration oil other than designated/specified Control the refrigerant purity. The purity is referred to Attachment 2.
- (8) Do not touch the compressor during the operation or immediately after ceasing operation. The compressor enclosure surface temperature may still be at a maximum temperature of 150°C. (if the designated parts are employed)
- (9) The safety instruction during inspection or repairs of the compressor shall be clearly instructed by the product procedures, manual and etc. of the unit and the work done must be made in accordance to those documents.
- (10) In the case of part replacement, use the correct and original part that is designated for the unit. Further, the wiring to the compressor shall be performed in accordance to the wiring diagram.

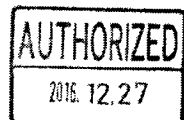

No	CE-100017E
Sheet.No	11-8

- (11) Use a circuit breaker to supply power.
- (12) In the case of 3-phase compressor, confirm that there is no wrong wiring which may cause reverse rotation of the compressor. It could become the cause of compressor burn and be dangerous.
- (13) If power supply is obtained from a generator, its frequency, waveform and voltage may not be as stable as commercial power supply. Therefore, ensure safety by performing a confirmation test.
- (14) Do not handling in a manner that could shock or apply excessive force to the glass of the hermetic terminal (bend of pins, impact, etc.). A crack can be a cause of leak, short circuit or etc. Please do not straighten the bended pins as this may cause chip-off or crack to the terminal and resulted into refrigerant leakage or short circuit.
- (15) Make sure that there is no foreign object and etc. on the 'hermetic terminal. The terminal cover must be fixed properly.
- (16) Do not touch the surface of compressors low pressure side (e.g., accumulator and etc.) as it's surface sometimes drop to a low temperature (-20°C or below).
- (17) Pay attention not to damage the pipe of the refrigeration cycle during inspection, repair work, compressor replacement, or choking the pipe with brazing residue during brazing
- (18) While performing leak test, use inert gas or dry nitrogen, and make sure that the leak test pressure is not in excess of the leak tight pressure mention in the compressor specification.

## **9.Safety request items during storage and transport (collective packing)**

- (1) The packing handling instruction mark is printed on external surface of the compressor packing material. Observe this handling instruction while handling the packing.
- (2) The transfer of collective packing must be made correctly by using forklift or etc., and attention must be given to avoid injury due to fall, drop and etc.
- (3) When stacking the packed items for storage, the number of stack must comply with the number indicated on the instruction mark and attention must be given to avoid injury due to fall, drop and etc.
- (4) If packing material is made from corrugated cardboard, do not store it in a humid place because it can cause the package to fall or topple.  
Also, do not store it outside irrespective of package style.
- (5) The compressor is a heavy product, so attention must be given to avoid injury occurred during unpacking and transport.
- (6) The packing material is constructed by corrugated cardboard, styrene foam (depending on the factory), PP band, wood and etc. The packing material must be store at a location that is not exposed to fire, flame or any place that has a risk for the packing material burn.

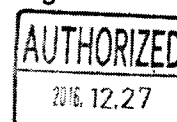

No	CE-100017E
Sheet.No	11-9

## **10. For usage of other than air-conditioner and freezer and water heater application**

For usage of other than air-conditioner and freezer and water heater application, please contact the inquiry office in following section.

## **11. Appeal for attention to end users and service personnel**

- (1) Be thorough in observing the safety items related to this safety instruction while conveying this information to end users and service personnel through the Installation Procedure, Service Manual, caution/warning labels, and etc.

**Panasonic Appliances Compressor (Dalian) Co., Ltd.**  
**DongHai Road, GanJingZi District, DaLian City, LiaoNing Province, China**  
**TEL: 86-0411-62658178**  
**FAX: 86-0411-86586556**

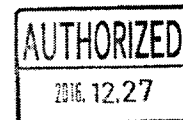

No	CE-100017E
Sheet.No	11-10

## Attachment1. Safety indication (warning label) on the compressor

The minimum handling warning or danger are indicated on the label of the compressor.  
(Refer to the followings)

- No damage or removal of this indication label is allowed.
- Be thorough in communicating this information to the compressor inspectors or repair personal to observe the warning.
- If this warning or danger label is difficult to be seen due to the structure of the unit, device a mean for safety warning on the unit, in the Repair and Inspection Manual and etc.

### <Contents of warning label of the compressor>

(Exemplified in the case of a scroll compressor)

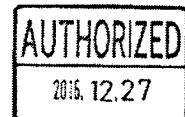
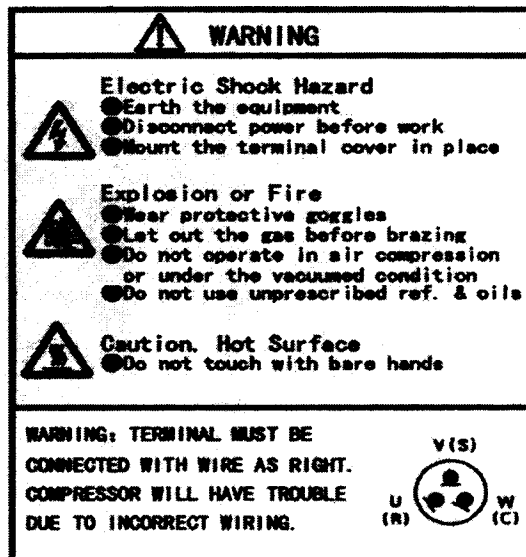

## Attachment2. Refrigerant Purity

No.	CE-100017E
Sheet.No	11-11

### HCFC-22

Purity	99.5 wt% min
Vapor Content	100 wt ppm max
Acid Content (HCl Conversion)	1 wt ppm max
Moisture Content	10 wt ppm max
Non-Condensable Gas	1.5 vol% max

### HFC-134a

Purity	99.5 wt% min
Vapor Content	100 wt ppm max
Acid Content (HCl Conversion)	1 wt ppm max
Moisture Content	10 wt ppm max
Non-Condensable Gas	1.5 vol% max

### HFC-407C

Structure : Composition (wt%)	HFC32 : 23 ± 2.0 wt% HFC125 : 25 ± 2.0 wt% HFC134a : 52 ± 2.0 wt%
Purity	Each composition at 99.5 wt% min
Vapor Content	100 wt ppm max
Acid Content (HCl Conversion)	1 wt ppm max
Moisture Content	10 wt ppm max
Non-Condensable Gas	1.5 vol% max

### HFC-410A

Structure : Composition (wt%)	HFC32 : 50 ± 1.5 wt% HFC125 : 50 ± 1.5 wt%
Purity	Each composition at 99.5 wt% min
Vapor Content	100 wt ppm max
Acid Content (HCl Conversion)	1 wt ppm max
Moisture Content	10 wt ppm max
Non-Condensable Gas	1.5 vol% max

### HFC-32

Purity	99.5 wt% min
Vapor Content	100 wt ppm max
Acid Content (HCl Conversion)	1 wt ppm max
Moisture Content	10 wt ppm max
Non-Condensable Gas	1.5 vol% max

### HFC-404A

Structure : Composition (wt%)	HFC125 : 44 ± 2.0 wt% HFC143a : 52 ± 2.0 wt% HFC134a : 4 ± 2.0 wt%
Purity	Each composition at 99.5 wt% min
Vapor Content	100 wt ppm max
Acid Content (HCl Conversion)	1 wt ppm max
Moisture Content	10 wt ppm max
Non-Condensable Gas	1.5 vol% max

AUTHORIZED

2016. 12.27

### R744 (CO2)

Purity	99.9 vol% min
Water Content	0.005 vol% max
Gas Impurities (H2, N2, O2, Ar)	0.01 vol% max
Total sulfur	0.03ppm max